

Powder-Coated

Powder-coated aluminum chassis is portable and heavy duty. Hammertone finish provides additional tire traction.

Polymer Ramps

Honeycomb/ribbed design for wheel traction and maximal strength-to-weight performance. Durable industrial polyurethane. Swivel folds for compact stowage and easy deployment and servicing. Swappable to dummy pads during weigh-in-motion use (AXA-8).

IP68 Waterproof

Industry-leading ingress protection rating of IP68 (NEMA 6P) enables outdoor use in harsh outdoor conditions.

Integrated Handles

Integrated handles on both sides of the scale pad for convenient handling and positioning.

600 Hour Battery

Standard 18650 li-ion battery housed in waterproof cover delivers 600 hours continuous use battery life. Rechargeable by USB-C, replaceable without tools, and upgradeable to low-temperature cells (down to -40C°/-40F°).

Ease of Alignment

Hi-Vis safety orange paint for visibility with engraved arrow markings for precise wheel alignment.

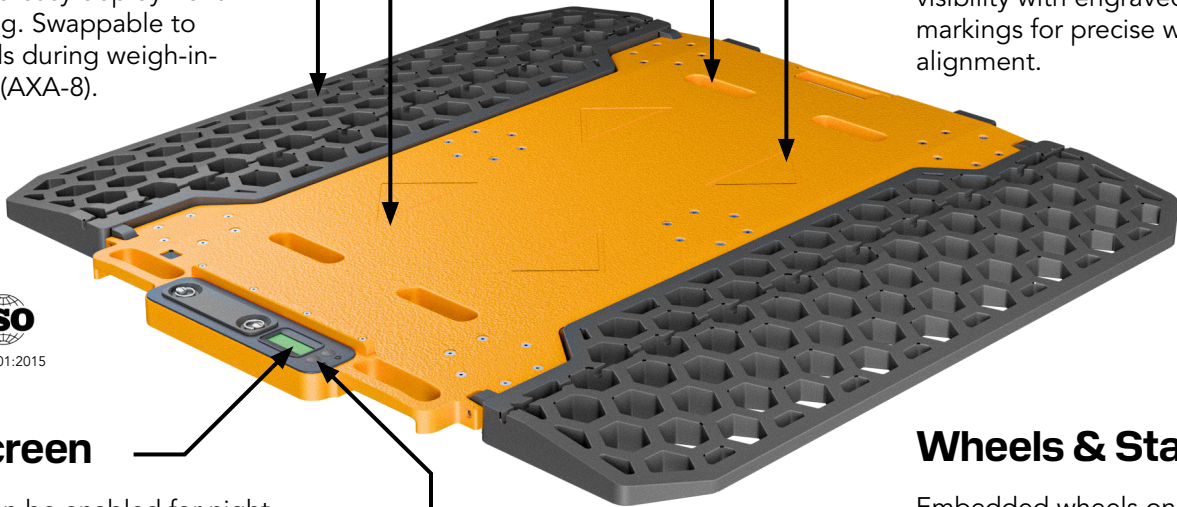

LCD Screen

Backlight can be enabled for night-time use with adjustable brightness. Screen is recessed to protect from wheel rollover damage. Displays measured values, stability, unit of measure, wireless connection, battery life.

Capacitive Switches

Raised capacitive touch switches allow power on/off, zeroing, and backlight functionality without compromising water resistance.

Wheels & Stands

Embedded wheels on the bottom of the scale allow for easier transport. Rubber stands provide protection and convenience when the scale is handled vertically.

Onboard Interface

Indications for battery life, connection strength to indicator, measurement value 0, WIM activation, unit of measure.

Two capacitance switches for:

- Power (ON/OFF) & Firmware Version
- ZERO & Backlight Adjustment
- Feature settings including brightness, automatic zero condition, unit switching, peak mode, wireless connection

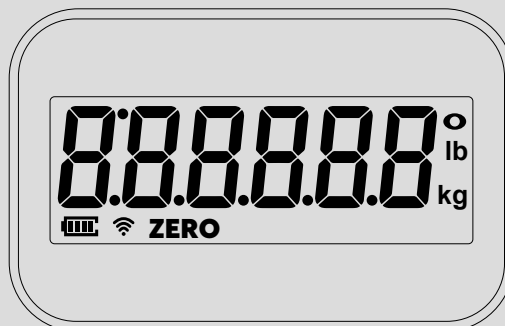

Specifications Table



Specifications	AXA-3			AXA-5		AXA-8		
Capacity (ton/lb)	0.5t 1Klb	1t 2Klb	2t 4Klb	3t 6Klb	5t 11Klb	10t 22Klb	15t 33Klb	20t 44Klb
Division (kg/lb)	0.2kg 0.5lb	0.5kg 1lb	1kg 2lb	1kg 2lb	2kg 5lb	10kg 20lb	10kg 20lb	10kg 20lb
Product Weight (Approx.)	6kg / 13lb			16kg / 35lb		19kg / 42lb		
	Including Ramp Weight					Excluding Ramp Weight		
Platform Size (mm/inch)	305 x 305 / 12" x 12"			500 x 370 / 19 ³ / ₄ " x 14 ¹ / ₂ "		800 x 500 / 31 ¹ / ₂ " x 19 ³ / ₄ "		
Platform Height (mm/inch)	24.5 / 1"			33 / 1 ³ / ₈ "				
WIM Speed	n/a			n/a		10kph / 6mph or less		
WIM Accuracy	n/a			n/a		±0.2%~±0.6%		

Shared Specifications

Static Accuracy	±0.1%~±0.3%
Transmission Range	Indoor: 30m / 100ft Outdoor: 300m / 1000 ft
Ramp (Dummy) Material	Urethane
Ramp Cover Material	Polycarbonate
Body Material	Aluminum, Hammer-Tone Powder Coating
Ingress Protection	IP68 (NEMA 6P)
Operating Temperature	-20°C~60°C / -4°F~140°F
Operating Humidity	85% R.H. (No Condensation)
Wireless Transmission	Zigbee with 128-bit AES Encryption
Operating Time	600 hrs (Continuous Usage)
Battery & Charger	Rechargeable 18650 Li-Ion + PCM with Standard Battery Charger
Display	6 Digit FSTN LCD (Height 11mm / 1/2in) & LED Backlight
Operating Switch	2 Capacitance Touch Switches
Safe Overload	150% FS

Accessories: Roll Up Dummy Pad (AXA-8 Only) & Transport Case

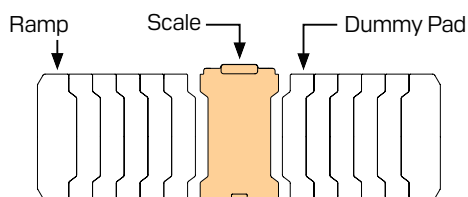

AXA Selection



AXA-3

0.5 - 2 ton / 1,000 - 4,000lb (Per Axle)

Static Weighing Accuracy: $\pm 0.1\% \sim \pm 0.3\%$

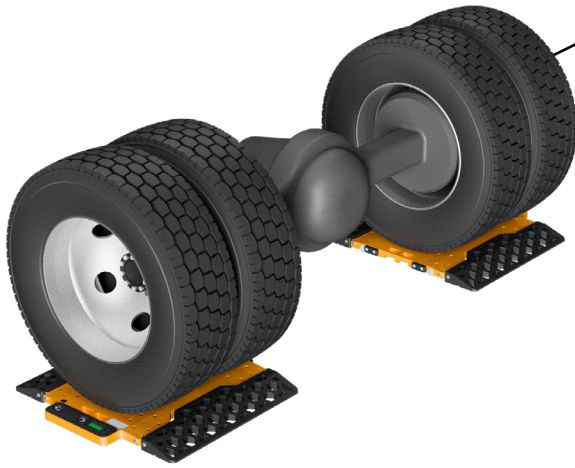
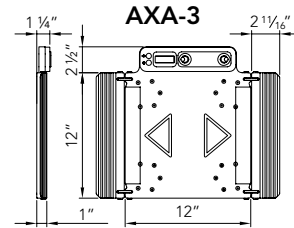

AXA-5

3 - 5 ton / 6,000 - 11,000lb (Per Axle)

Static Weighing Accuracy: $\pm 0.1\% \sim \pm 0.3\%$

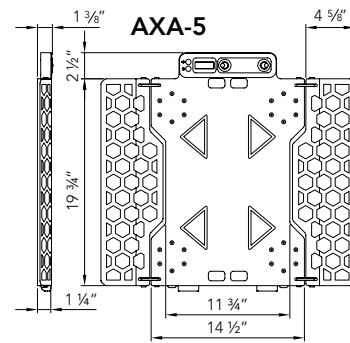

AXA-8

10 - 20 ton / 22,000 - 44,000lb (Per Axle)

Weigh-In-Motion (WIM) Accuracy: $\pm 0.2\% \sim \pm 0.6\%$

* Paired with AN560 indicator & dummy pads

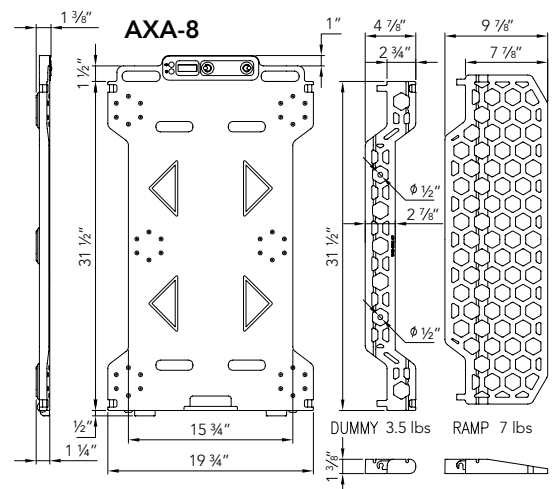

Static Weighing Accuracy: $\pm 0.1\% \sim \pm 0.3\%$

AN560 Wireless Indicator

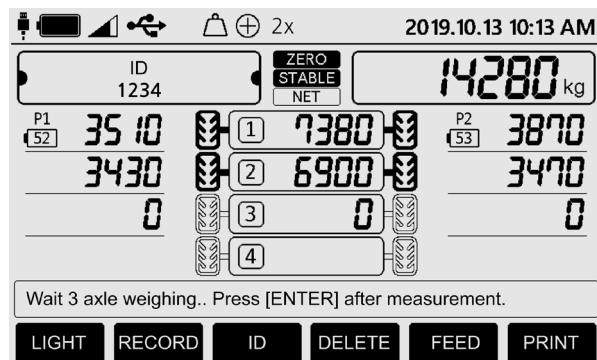

Specifications	AN560
Data Export	USB Flash, USB Virtual COM
Number of Scales	Up to 8
Memory	99,999 Axles 1000 Trucks
Ingress Protection	IP67
Battery Type	USB Rechargeable
Battery Life	600hrs Continuous Usage
Size (mm/inch)	292 x 248 x 121mm / 11½ x 9¾ x 4¾ in
Product Weight	3kg / 6lb
Display	E-Ink 4.2"

Rugged Hard-Shell Case



Built for mobile use in harsh environments including roadside sites, construction zones, and aviation ramps.

Key Features

- E-Ink Display with Backlight**
 Ultra-readable in direct sunlight and at night. The non-backlit panel minimizes glare and eye strain during extended outdoor use.
- Built-in Thermal Printer**
 Generate instant records and receipts of axle weights, overload alerts, and vehicle summaries.
- 24 Key Tactile Keypad**
 Includes navigation, numeric entry, and hotkeys for zeroing, printing, and vehicle ID input.
- Balancing Mode for Multi-Pad Systems**
 Use with up to eight pads to evaluate weight distribution. Ideal for race teams, transport safety checks, and mobile inspections.
- Vehicle Classification & Record Management**
 Define and recall preset axle layouts. Search stored weighments by date, vehicle ID, serial number, or overload status.
- Ultra-Portable (3 kg)**
 Can be held by one hand while the other operates the indicator.