

# 363TSM1

Compression Weigh Module

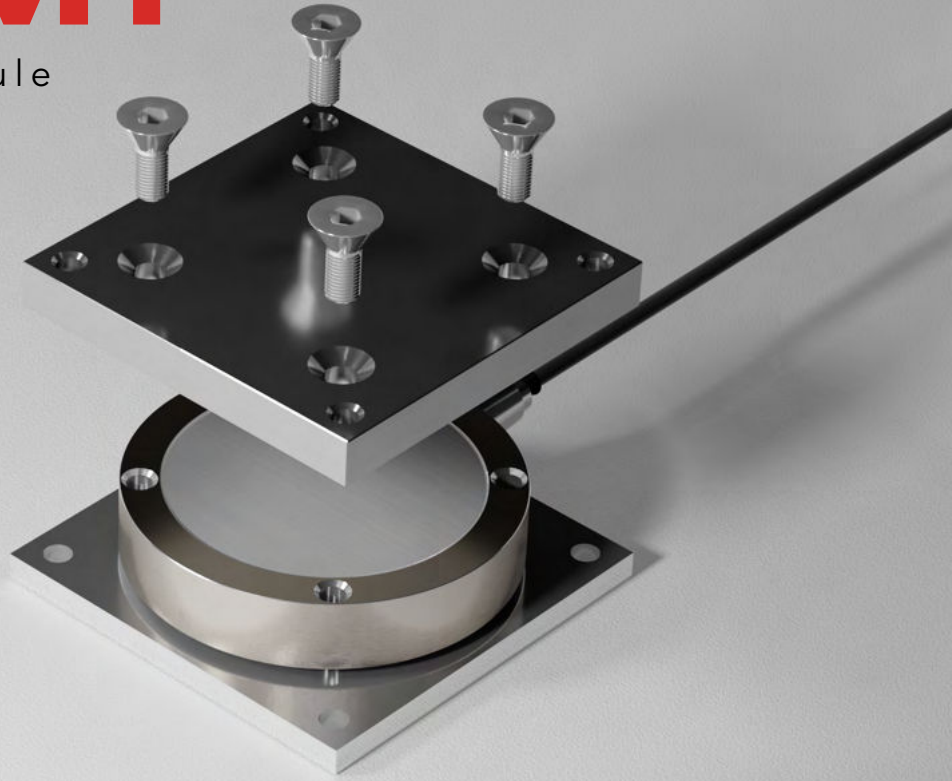
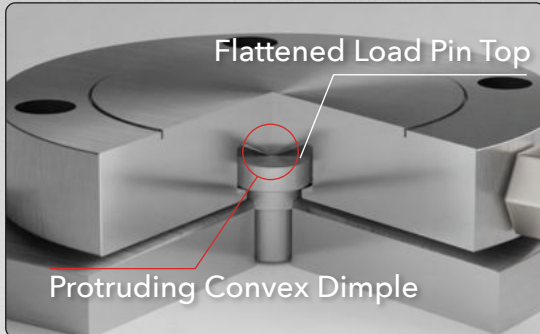

## Specifications

**Rated Capacities:** 1Klb, 2.5Klb, 5Klb, 10Klb, 25Klb, 50Klb, 100Klb, 200Klb

**Full Scale Output:** 3mV/V  $\pm$  0.25%

**Non-linearity, Hysteresis Error:**

Cap. < 2.5Klb: <  $\pm$  0.05%;

Cap. = 5Klb-25Klb: <  $\pm$  0.1% or <  $\pm$  0.3%; Cap. = 50Klb: <  $\pm$  0.3%

**Safe Overload:** 150% of full scale

**Breaking Overload:** 300% of full scale

**Lift & Side Protection:** 50% of rated capacity

**Seal Type:** Hermetically Sealed

**IP Rating:** IP68/IP69K

## Features

### *ThinWeigh*<sup>®</sup>

- 17-4 PH Stainless Steel
- High Capacity Ultra Low-Profile Mount
- Integrated Rocker Pin allows for 360° Thermal Expansion
- Natural tolerance for  $\leq 3^\circ$  irregular loading
- 50% of R.C. uplift and side load protection
- Top plate (optional)





## Description

The 363TSM1 ThinWeigh® leads the industry as an integrated compression weigh module that is high capacity and ultra low-profile, ideally suited for tank, hopper, and vessel weighing. Our patented internal design significantly improved accuracy and repeatly compared to the traditional load pin design while also improving performance under variable loading conditions and temperature fluctuations. The ThinWeigh® is a superior alternative to conventional weigh modules.

## Diagram - 363TSM1

