

106MH-ES-F

Stainless Steel

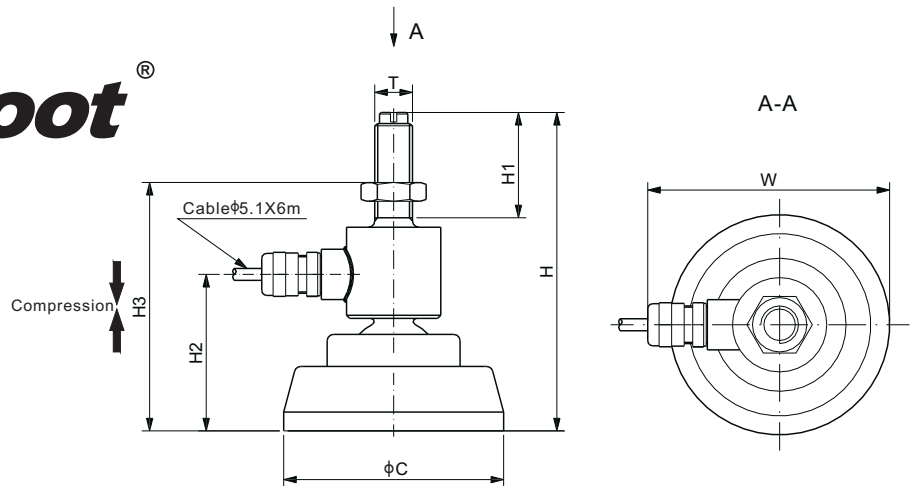

CE RoHS

DIMENSIONS

RATED CAPACITY	C	H	H1	H2	H3	W	T
t/mm							
0.5-1	70.0	101.3	33.5	51.8	76.0-99.0	77.0	M12
2	70.0	119.8	50.0	51.8	78.0-116.0	77.0	M16
5	80.0	132.8	55.0	59.8	87.0-127.0	82.0	M20
10	100.0	187.3	80.0	81.3	118.0-180.0	96.0	M24×2
Klb/inches							
1-2.5	2.76	3.99	1.32	1.96	2.99-3.90	3.03	1/2-20 UNF
5-10	3.15	5.23	2.17	2.35	3.43-5.00	3.23	3/4-16 UNF
20	3.94	7.37	3.15	3.20	4.65-7.09	3.78	1-14 UNS

SPECIFICATIONS

Full Scale Output	2.0 mV/V ± 0.25%	Recommended Excitation	10V (15V Maximum)
Zero Balance	± 0.02 mV/V	Insulation Resistance	>2 [50V DC] GΩ
Non-linearity	Cap. ≤ 2t: < ± 0.050%; Cap. > 2t: < ± 0.2%	Compensated Temperature Range	-10°C to 50°C / 14°F to 122°F
Repeatability	< ± 0.030%	Safe Overload	150% of full scale
Hysteresis Error	< ± 0.050%	Breaking Overload	300% of full scale
Creep in 30 min.	< ± 0.030%	Seal Type / IP Rating	Welded Seal / IP67
Input Resistance	380Ω ± 20	Cable Color Code	Exc+ Red Exc- Black
Output Resistance	350Ω ± 3		Sig+ Green Sig- White
Element Material	2Cr13 Stainless Steel		Shield Bare

PART NUMBER

Rated Capacity	Part No.	Shipping Weight (kg) Approx.
500kg.....	106MH-ES-F-500kg.....	1.0
1t.....	106MH-ES-F-1t.....	1.0
2t.....	106MH-ES-F-2t.....	1.0
5t.....	106MH-ES-F-5t.....	-
10t.....	106MH-ES-F-10t.....	-
1Klb.....	106MH-ES-F-1Klb.....	1.0
2.5Klb.....	106MH-ES-F-2.5Klb.....	1.0
5Klb.....	106MH-ES-F-5Klb.....	-
10Klb.....	106MH-ES-F-10Klb.....	-
20Klb.....	106MH-ES-F-20Klb.....	-

CANISTERS & DISKS