

# 363TSM1

## Stainless Steel, US Patent Pending

WEIGH MODULES

### ThinWeigh™

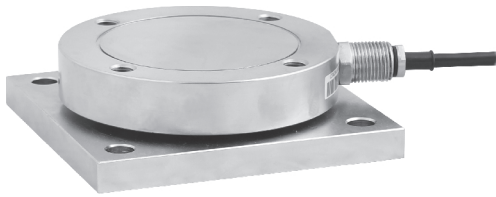

#### Features:

- Simple installation for tank, hopper & silo weighing
- High capacity 1Klb to 200Klb in a very low profile
- Hygienic design impervious to dirt & debris
- All stainless steel hermetic seal to IP68/IP69K
- Allows for 360° Thermal Expansion
- 50% of full scale side load & up lift protection
- Available option: Alloy Steel material (model name: 363THM1 for 100Klb and 200Klb only)

Mounting Top Plate (not shown in the picture): to order separately

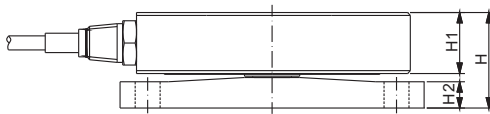

Capacity ≤ 10Klb/5t : Cable φ 5.1X6m  
Capacity ≥ 25Klb/12t : Cable φ 7.6X6m

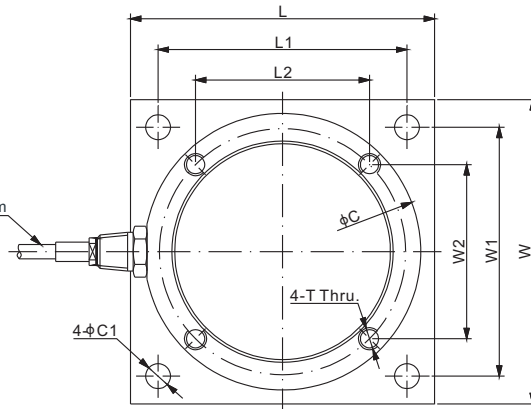

#### DIMENSIONS

RATED CAPACITY	C	C1	H	H1	H2	L	L1	L2	W	W1	W2	T
<b>Klb/inches</b>												
1-2.5	3.94	0.35	1.02	0.65	0.26	4.33	3.54	2.48	4.33	3.54	2.48	5/16-18 UNC-2B
5-10	4.72	0.43	1.40	0.93	0.33	5.12	4.33	3.00	5.12	4.33	3.00	3/8-16 UNC-2B
25-50	5.75	0.53	2.09	1.38	0.55	6.22	4.92	3.51	6.22	4.92	3.51	1/2-20 UNF-2B
100	8.43	0.83	3.07	1.97	0.83	9.84	8.11	4.98	9.84	8.11	4.98	3/4-16 UNF-2B
200	9.84	1.06	3.82	2.32	1.14	11.22	8.86	5.76	11.22	8.86	5.76	1-14 UNS-2B
<b>t/mm</b>												
0.5-1.2	100.0	9.0	26.0	16.5	6.5	110.0	90.0	62.9	110.0	90.0	62.9	M8×1.25
2.5-5	120.0	11.0	35.5	23.5	8.5	130.0	110.0	76.4	130.0	110.0	76.4	M10×1.5
12-25	146.0	13.5	53.0	35.0	14.0	158.0	125.0	89.1	158.0	125.0	89.1	M12×1.75
50	214.0	21.0	78.0	50.0	21.0	250.0	206.0	126.6	250.0	206.0	126.6	M18X2.5
100	250.0	27.0	97.0	59.0	29.0	285.0	225.0	146.4	285.0	225.0	146.4	M24X3

#### SPECIFICATIONS

<b>Full Scale Output</b>	3.0 mV/V ± 0.25%	<b>Element Material</b>	17-4PH Stainless Steel
<b>Zero Balance</b>	Cap. ≤ 1.2t/2.5Klb: ≤ ± 0.04 mV/V	<b>Recommended Excitation</b>	10V (15V Maximum)
	Cap. ≥ 2.5t/5Klb: ≤ ± 0.02 mV/V	<b>Insulation Resistance</b>	>2 [ 50V DC ] GΩ
<b>Non-linearity</b>	Cap. ≤ 1.2t/2.5Klb: < ± 0.05%;	<b>Thermal Expansion / Contraction or Minor Misalignment</b>	500kg - 5t / 1K - 10Klb: 2mm 12t - 100t / 25Klb - 50t: 3mm
	Cap.: 2.5t-12t/5K-25Klb: < ± 0.1% or < ± 0.3% Cap. ≥ 25t/50Klb: < ± 0.3%	<b>Compensated Temperature Range</b>	-10°C to 50°C / 14°F to 122°F
<b>Repeatability</b>	< ± 0.05%	<b>Safe Overload</b>	150% of full scale
<b>Hysteresis Error</b>	Cap. ≤ 1.2t/2.5Klb: < ± 0.05%;	<b>Breaking Overload</b>	300% of full scale
	Cap.: 2.5t-12t/5K-25Klb: < ± 0.1% or < ± 0.3% Cap. ≥ 25t/50Klb: < ± 0.3%	<b>Lift Protection</b>	50% of full scale
		<b>Side Protection</b>	50% of full scale
<b>Creep in 30 min.</b>	< ± 0.05%	<b>Seal Type / IP Rating</b>	IP68 / IP69K
<b>Input Resistance</b>	700Ω ± 10	<b>Cable Color Code</b>	Exc+ Red Exc- Black
<b>Output Resistance</b>	700Ω ± 5		Sig+ Green Sig- White Shield Bare

#### AVAILABLE OPTIONS

- Alloy Steel construction: 363THM1 (for 100Klb and 200Klb only)

PART NUMBER		
Rated Capacity	Part No.	Weight (kg) Approx.
1Klb.....	363TSM1-1Klb.....	-
2.5Klb.....	363TSM1-2.5Klb.....	2.0
5Klb.....	363TSM1-5Klb.....	3.2
10Klb.....	363TSM1-10Klb.....	3.2
25Klb.....	363TSM1-25Klb.....	7.4
50Klb.....	363TSM1-50Klb.....	7.4
100Klb.....	363TSM1-100Klb.....	-
200Klb.....	363TSM1-200Klb.....	43.0

PART NUMBER		
Rated Capacity	Part No.	Weight (kg) Approx.
500kg.....	363TSM1-500kg.....	-
1.2t.....	363TSM1-1.2t.....	2.0
2.5t.....	363TSM1-2.5t.....	3.2
5t.....	363TSM1-5t.....	3.2
12t.....	363TSM1-12t.....	7.4
25t.....	363TSM1-25t.....	7.4
50t.....	363TSM1-50t.....	-
100t.....	363TSM1-100t.....	43.0

### MOUNTING TOP PLATE

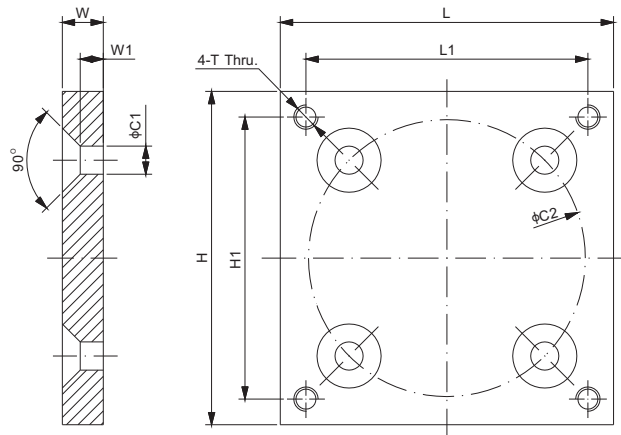

### DIMENSIONS

RATED CAPACITY	C1	C2	H	H1	L	L1	W	W1	T
<b>Klb/inches</b>									
1-2.5	0.35	3.50	4.33	3.54	4.33	3.54	0.50	0.24	5/16-18 UNC-2B
5-10	0.43	4.25	5.12	4.33	5.12	4.33	0.63	0.35	3/8-16 UNC-2B
25-50	0.53	4.96	6.22	4.92	6.22	4.92	0.79	0.47	1/2-20 UNF-2B
100	0.83	7.05	9.84	8.11	9.84	8.11	1.00	0.55	3/4-16 UNF-2B
200	1.06	8.15	11.22	8.86	11.22	8.86	1.50	0.91	1-14 UNS-2B
<b>t/mm</b>									
0.5-1.2	9.0	89.0	110.0	90.0	110.0	90.0	12.7	6.2	M8×1.25
2.5-5	11.0	108.0	130.0	110.0	130.0	110.0	16.0	9.0	M10×1.5
12-25	13.5	126.0	158.0	125.0	158.0	125.0	20.0	12.0	M12×1.75
50	21.0	179.0	250.0	206.0	250.0	206.0	25.4	13.9	M18X2.5
100	27.0	207.0	285.0	225.0	285.0	225.0	38.1	23.1	M24X3

PART NUMBER		
Rated Capacity	Part No.	Weight (kg) Approx.
1Klb-2.5Klb.....	TP363TSM1-(1-2.5)Klb.....	1.3
5Klb-10Klb.....	TP363TSM1-(5-10)Klb.....	2.2
25Klb-50Klb.....	TP363TSM1-(25-50)Klb.....	4.0
100Klb.....	TP363TSM1-100Klb.....	13.0
200Klb.....	TP363TSM1-200Klb.....	25.0

PART NUMBER		
Rated Capacity	Part No.	Weight (kg) Approx.
0.5t-1.2t.....	TP363TSM1-(0.5-1.2)t.....	1.3
2.5t-5t.....	TP363TSM1-(2.5-5)t.....	2.2
12t-25t.....	TP363TSM1-(12-25)t.....	4.0
50t.....	TP363TSM1-50t.....	13.0
100t.....	TP363TSM1-100t.....	25.0