

Aluminum

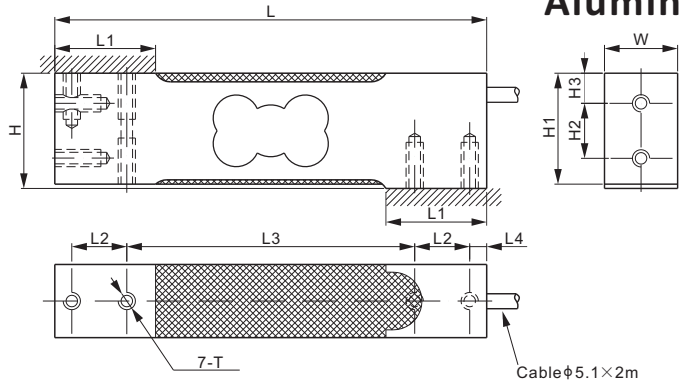

DIMENSIONS

RATED CAPACITY	H	H1	H2	H3	L	L1	L2	L3	L4	W	T
108TA: kg/mm 3-200	40.0	38.5	19.1	10.5	150.0	35.0	19.1	100.0	5.9	25.4	M6 Depth16
lb/inches (conversion of above dimensions) 6.61-440.92	1.57	1.52	0.75	0.41	5.91	1.38	0.75	3.94	0.23	1.00	M6 Depth0.6
108TAUN: kg/mm 3-200	40.0	38.5	19.1	10.5	150.0	35.0	19.1	100.0	5.9	25.4	1/4-20UNC-2B Depth16
lb/inches (conversion of above dimensions) 6.61-440.92	1.57	1.52	0.75	0.41	5.91	1.38	0.75	3.94	0.23	1.00	1/4-20UNC-2B Depth0.6

SPECIFICATIONS

Full Scale Output	2.0 mV/V ± 10%	Recommended Excitation	10V (15V Maximum)
Zero Balance	± 0.02 mV/V	Reference Max. Platform Size	400 × 450 mm
Non-linearity	< ± 0.017%	Insulation Resistance	> 2 [50V DC] G Ω
Repeatability	< ± 0.017%	Nominal Temperature Range	-10°C to 40°C / 14°F to 104°F
Hysteresis Error	< ± 0.017%	Safe Overload	150% of full scale
Creep in 30 min.	< ± 0.023%	Breaking Overload	300% of full scale
Input Resistance	415 Ω ± 15	Seal Type / IP Rating	Environmentally Sealed / IP66
Output Resistance	350 Ω ± 3	Cable Color Code	Exc+ Red Exc- Black Sig+ Green Sig- White Shield Bare
Element Material	Aluminum		

PART NUMBER

Rated Capacity	Part No.	Weight (kg) Approx.
3kg	108TA-3kg	0.4
	108TAUN-3kg	0.4
5kg	108TA-5kg	0.4
	108TAUN-5kg	0.4
7kg	108TA-7kg	0.4
	108TAUN-7kg	0.4
10kg	108TA-10kg	0.4
	108TAUN-10kg	0.4
15kg	108TA-15kg	0.4
	108TAUN-15kg	0.4
20kg	108TA-20kg	0.4
	108TAUN-20kg	0.4
30kg	108TA-30kg	0.4
	108TAUN-30kg	0.4
50kg	108TA-50kg	0.4
	108TAUN-50kg	0.4
75kg	108TA-75kg	0.4
	108TAUN-75kg	0.4
100kg	108TA-100kg	0.4
	108TAUN-100kg	0.4
150kg	108TA-150kg	0.4
	108TAUN-150kg	0.4
200kg	108TA-200kg	0.4
	108TAUN-200kg	0.4

INTERCHANGEABLE PRODUCTS

Manufacturer

Model

108TA

Flintec.....PC42 (20-150kg)*
Vishay Revere Transducers.....642C
Vishay Tedeia-Huntleigh.....1042(metric threads)

108TAUN

Cardinal.....TSP
Coti Global.....CG-42
HBM.....SP4
Rice Lake.....RL1042
Rice Lake.....RLSP4
Vishay Revere Transducers.....642
Vishay Tedeia-Huntleigh.....1042(imperial threads)

* Flintec PC42 has a M8 mounting hole



NTEP 1:5 000 Class III, Single Cell



5kg-30kg: OIML MAA C4, Y=15 000;
50kg-200kg: OIML MAA C5, Y=12 300