

WL100 – Wireless Load Cell Manual

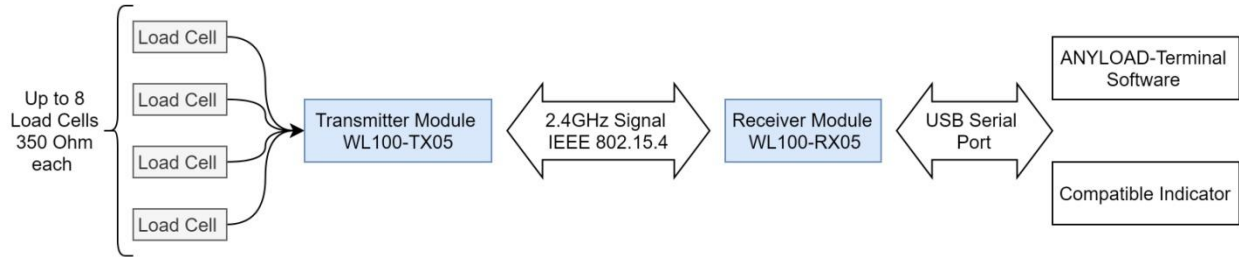

Kit Content

As part of the wireless system you will have the following:

1. 1X Wireless Transmitter Box
2. 1X Load Cell connector (CCS7-L)
3. 1X Receiver Box
4. Software Package (Zip file)

Load Cell Connector Wiring Guide

Please attach your load cell wires to the connector according to the following:

- Excitation Positive Ex+ (Red) → Pin 1
- Signal Positive S+ (Green) → Pin 2
- Excitation Negative EX- (Black) → Pin 3
- Signal Negative S- (White) → Pin 4
- Shield → Pin 5

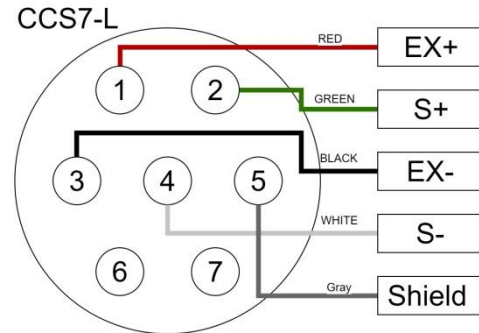

Please make sure of good solder connection and that no two wires are shorting to each other.

Note that if you are connecting more than one load cell to the transmitter module, a junction box will be required. The transmitter module is capable of powering up to 8 load cells with each having 350 Ω bridge resistance. Power consumption will be higher by adding more load cells. Assuming a sampling rate of 1 Hz, 4 AA batteries will last for 10 months if one load cell is connected and 2 months if 8 load cells are connected.

Important Notes and Warnings

- The transmitter is not an AC power device. **Power with DC only.**
- **DO NOT power the transmitter with more than 6V DC.**
- The transmitter does not have reverse polarity protection. Make sure of polarity before supplying power. **Connecting power in reverse will damage the board.**

- DO NOT connect load cell combinations with less than 40Ω bridge resistance.
- DO NOT position the transmitter or the receiver close to metal objects and make sure there are no metal barriers between the transmitter and receiver.

Hardware Setup Instructions

Open the transmitter box and install 4 standard AA batteries (not included) in the battery pack.

Connect the load cell wires to the provided connector according to the diagram above.

Plug in the load cell connector to the transmitter box. Make sure to do this before turning on the transmitter. (Note that turning on the transmitter without connecting a load cell will not damage the board, however the transmitter will be sending meaningless data to receiver).

To turn the transmitter on, press the switch on the transmitter box. The Transmitter is turned on when the switch is in a low profile position.

When the transmitter is transmitting at 1 sample per second (1 Hz), the power consumption is very low that 4 AA batteries can last 10 months. However, to conserve battery for even longer battery life, remember to turn off the transmitter when not in use for long periods of time.

Software Setup Instructions

The ANYLOAD Terminal Software is Windows based software running on 64bit architecture. The software comes as a compressed zip file containing the main executable and other supplementary files associated with the program. Please refrain from changing the directory structure, renaming or moving of files outside the main directory.

Requirements:

Please install **Java8** on your computer before running the executable provided. Link:
<https://www.java.com/en/download/>

Once Java8 is installed, make sure the receiver is plugged in to your computer. Please disconnect all other serial communication and USB ports from your computer except for mouse and keyboard.

When the receiver is plugged in, launch the “ANYLOAD_Terminal_V5_1” software.

Software Usage Instructions

The software has three different view modes based on access rights: User, Settings, and Calibration. Each of these modes is presented below.

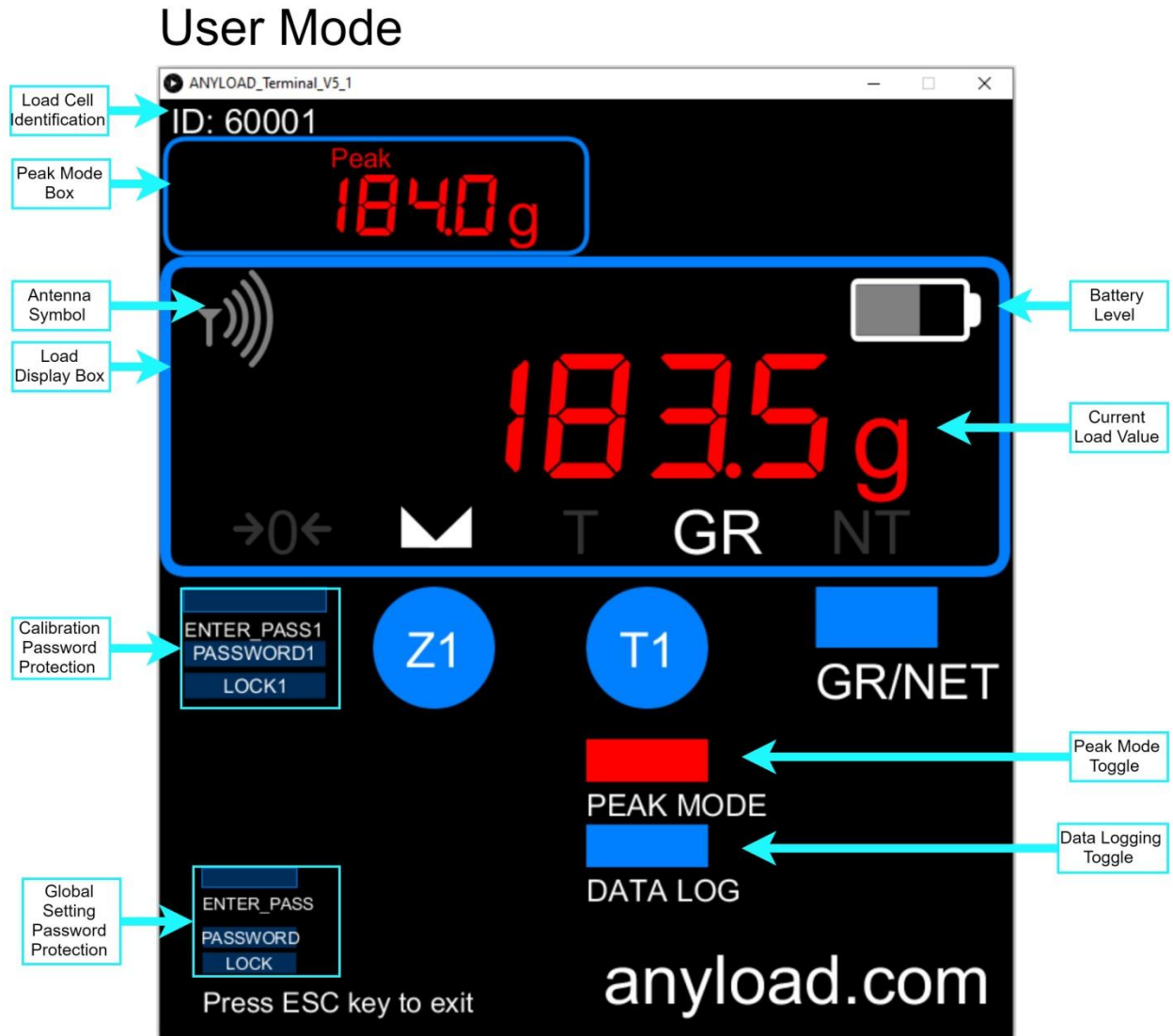

In the user mode, the operator can only interact with the software using the commands below:

Command	Description
PEAL MODE	Toggle the peak mode box
DATA LOG	Toggles logging of generated data
Z1	Zero the display
T1	Set/Remove Tare
GR/NET	Toggle between Gross and Net weight

Settings Mode



To activate the Settings Mode, the operator needs to enter the Global Setting Password. In Settings Mode, the operator can use the following commands in addition to the commands in User Mode:

Command	Description
RATE	Change the sampling rate of the Transmitter Module
UNITS	Change the display unit
DECIMAL	Change the number of decimal points being displayed
LOCK	Lock the Global Settings

Calibration Mode



To activate the Calibration Mode, the operator needs to enter the calibration password. Note that the password for Global Settings and Calibration is different. In Calibration Mode the operator can access the following commands in addition to the commands in User Mode:

Command	Description
DEAD_LOAD1	Click this after removing all weights from the load cell to set the true zero of load cell.
CAPACITY1	Click this after inputting the rated capacity in the WEIGHT1 field.
CAL_LOAD1	<ul style="list-style-type: none"> Put a known weight on load cell Enter the value of the known weight in the WEIGHT1 field Click CAL_LOAD1 for calibrating
ID1	Enter the ID of transmitter module in the ID_FIELD1, and click the ID1 button. This will reset all calibration parameters and change the sensor ID.

The commands are explained in more detail below:

Linking Software with Load Cell Transmitter/Receiver Pair

- To link the software with the transmitter/receiver pair, first make sure:
 - The transmitter is connected to the load cell and is powered on
 - The receiver is connected to PC (also disconnecting all other USB serial ports).
 - The last 4 digits of serial number of transmitter and receiver match
- Launch the “Anyload_Terminal_V5_1.exe” file
- Enter the calibration password in the box “ENTER_PASS1”.
- Then click “PASSWORD1”. [Password will be given in an Email separately].
- In the “ID_FIELD1” enter the last 5 digits of the serial number of transmitter. For example if the serial number is 8719060005, then you should enter 60005 in the ID_FIELD.
- Click the “ID1” button.
- This will change the Sensor ID parameter in the program and reset all calibration.
- If the transmitter is on and receiver is plugged in, you will see the antenna symbol changing from 2 bar to 4 bar and vice versa, indicating signal reception.

Load Cell Calibration:

- To start the calibration process, make sure your load cell is connected to the transmitter.
- Enter the calibration password in the box “ENTER_PASS1”. (Note that the suffix “1” is for programming purposes and can be ignored). Then click “PASSWORD1”. [Password will be given in an Email separately].
- Once the correct password is entered, the calibration commands will appear.
- In the number input field “WEIGHT1” enter your load cell capacity in the units selected from the Global Settings field. The default value is set to 10000 g (10 Kg). Then click “CAPACITY1”.
- Make sure there is no load on the load cell, and click “DEAD_LOAD1”. This should make the number on the display go to zero (or fluctuate around zero).
- Load the load cell with a known weight (ideally more than 80% of the maximum capacity), and click “CAL_LOAD1”. The display should show the correct value of the known weight. When loading the load cell, make sure not to overload or shock the load cell. The overload threshold is set to 2% of the maximum capacity.
- To change the division (display accuracy) of the load cell, use the dropdown “DIVISION1” menu.
- Once the steps above are done, click on “LOCK1”, to lock in the calibration values.

Global Settings:

The global settings are activated by entering the global setting password in the password field “ENTER_PASS” and click on “PASSWORD”. [Password will be given in an Email separately].

- Use the “UNITS” drop down menu to change units. (default is in grams)
- Use the “DECIMAL” drop down menu to change display decimal digits. (default is in 1 decimal point)
- Use the “RATE” drop down menu to change the load cell sampling rate. (default is 2 Hz)

User Action Buttons:

- Use the “Z1” to zero display.

- Use the “T1” to tare display.
- When the Tare symbol “T” is active, use the “GR/NET” button to switch between the Gross and Net weight.
- Use the “PEAK MODE” toggle switch to activate (red color) and deactivate (blue color) the Peak Mode Box. The Peak Mode displays the maximum value of the load display from when it is activated. The peak mode display resets when deactivated.
- Use the “DATA LOG” toggle switch to activate (red color) and deactivate (blue color) the data logging function. When active, all the display data will be recorded as a date and time stamped CSV file. The file will be saved to the same directory as the main program executable.

The battery symbol shows the battery level of the related transmitter. This level is based on 4 AA battery pack (nominal 6V).

The antenna symbol will change shape from 2 bars to 4 bars and vice versa on every signal reception.

Exiting Application

To **Exit the application and save settings** and calibration data, press the **ESC** key on your keyboard.

To **Exit the application without saving** settings click the **X** mark at the top right corner of the application window.

Troubleshooting Guide (Q&A):

Q: There is nothing showing on the display?

A: Make sure of the following:

- Load cell is connected to the transmitter
- Transmitter is powered on
- The last 5 digits of the Transmitter, Receiver are the same
- The correct ID is set on the software application

Q: There is a message “OverLoaded Load Cell. Contact Anyload” that will not disappear?

A: This is caused by:

- Powering on the transmitter and running the Terminal application before connecting the load cell
- Entering incorrect values for capacity of load cell
- Incorrect calibration
- Shock loading of load cell
- Overloading of load cell
- Load cell was disconnected while program is running

To solve the issue of “Overload” message on the display, we will have to issue a replacement software suit specific to your device. Call us and provide the serial number of your transmitter and receiver.

Q: The application starts with a grayed out screen?

A: Make sure of the following:

- The computer is a 64 bit Windows machine.
- You have Java 8 installed: <https://www.java.com/en/download/>
- The receiver is plugged in the computer.
- You have disconnected all other serial communication and USB ports (except for mouse and keyboard) from the computer.







Q: The display updates randomly and does not match the sampling rate?

A: The transmitter and receiver pair has an unobstructed transmission range of 1000 meters and obstructed transmission range of 70 meters. However if the obstruction between the transmitter and receiver is metallic in nature or has water content, then this range will become shorter. Common examples of radio blocking barriers include sheet metal, reinforced concrete with rebar, extreme rain or humidity, submerged transmitter unit in water, underground transmitter with high water content ground (mud), water saturated wood barrier, etc.

To solve this problem, make sure of the following:

- Do not have a distance of more than 1000 meters outdoors (line of sight) and 70 meters indoors (no radio blocking barriers).
- If the distance between the transmitter and receiver is between 70 meters and 1000 meters, do not have any obstructions between transmitter and receiver.
- Do not have any radio blocking barriers between transmitter and receiver.
- Do not submerge the transmitter in water or mud.

Regulatory Information

Region	Approval	Approval ID	Description
United States		MCQ-XBEE3	Complies with FCC Part 15
Europe		XBEE3	EN 62368-1:2014 EN 62311:2008 EN 301 489-1 V2.1.1 (2017-02) EN 301 489-17 V3.1.1 (2017-02) EN 300 328 V2.1.1 (2016-11) EN 50581:2012
Canada		IC: 1846A-XBEE3	Innovation, Science and Economic Development Canada (ISED). Complies with Industry Canada license-exempt RSS standard(s).
Japan	 R210-119309	210-119309	Complies with Japan MIC Article 2 Paragraph 1, Item 19
Brazil	 06329-18-01209	06329-18-01209	Complies with the requirements of ANATEL to be used in Brazil
South Korea	 R-C-DIG-XBEE3	R-C-DIG-XBEE3	Complies with South Korea's Korea communications Commission (KCC) Clause 2, Article 58-2 of Radio Waves Act

RF exposure

CAUTION! To satisfy FCC RF exposure requirements for mobile transmitting devices, a separation distance of 20 cm or more should be maintained between the antenna of this device and persons during device operation. To ensure compliance, operations at closer than this distance are not recommended. The antenna used for this transmitter must not be collocated in conjunction with any other antenna or transmitter.