

Stainless Steel

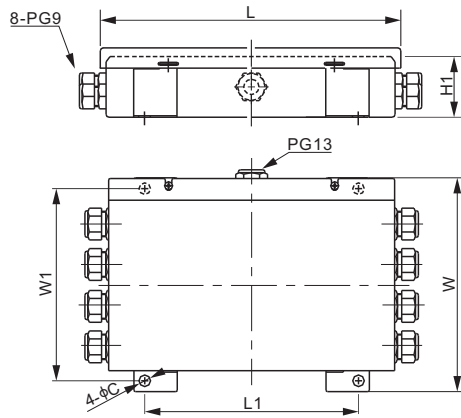
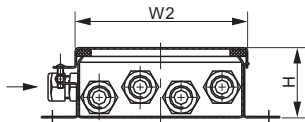
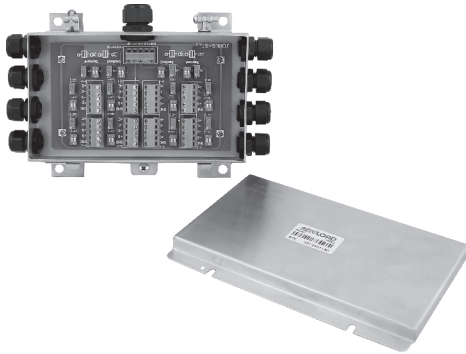

Features:

- Enclosure Material: Stainless steel SS304
- Number of cells: 2 - 8 single cells
- Trimming: Section or individual cell trim, with excitation or signal trim
- Equipped with independent adjustable resistors
- Captive stainless steel screws
- IP Rating: IP65

DIMENSIONS

	C	H	H1	L	L1	W	W1	W2
mm	8	43	40	200	147	147	134	119
inches	0.3	1.7	1.6	7.9	5.8	5.8	5.3	4.7

SPECIFICATIONS

Number of Cells	2 - 8 single cells	Trimming	Section or individual cell trim, with excitation or signal trim
Input Cable Fittings	PG9: 4mm - 8mm diameter cable	Enclosure Material	Stainless steel SS304
Output Cable Fittings	PG13: 6mm - 12mm diameter cable	IP Rating	IP65

TRIMMING RANGE

Load Cell Resistance	Signal Trim	Excitation Trim
350Ω	3.6% of output	2.3% of output
700Ω	6.3% of output	1.3% of output
1000Ω	7.0% of output	1.0% of output

PART NUMBER

Trimming	Section Trim	Lightning Protection	Part No.	Weight (kg) Approx.
Excitation	Yes	No	J08ES	1.0
Signal	Yes	No	J08SS	1.0
Excitation	No	No	J08ES-I	1.0
Signal	No	No	J08SS-I	1.0
Excitation	No	Yes	J08ES-II	1.0
Signal	No	Yes	J08SS-II	1.0
Excitation	Yes	Yes	J08ES-III	1.0
Signal	Yes	Yes	J08SS-III	1.0

MOTHERBOARD LAYOUT

