

363TSM1

Stainless Steel, Patent Pending

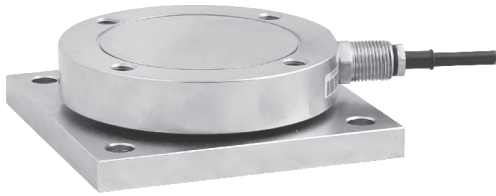

Features:

- Unique design with super thin profile, suitable for tank & hopper weighing or other weighing application
- Stainless steel construction, hermetic sealed
- Hygienic design, great for food & chemical industrial
- Special internal design to tolerate thermal expansion, contraction or minor misalignment
- Withstand side load & lift up to 50% of full scale
- Load Cell can tilt up to 3 degree from Base Plate

Capacity ≤ 10Klb/5t : Cable φ 5.1X6m
 Capacity ≥ 25Klb/12t : Cable φ 7.6X6m

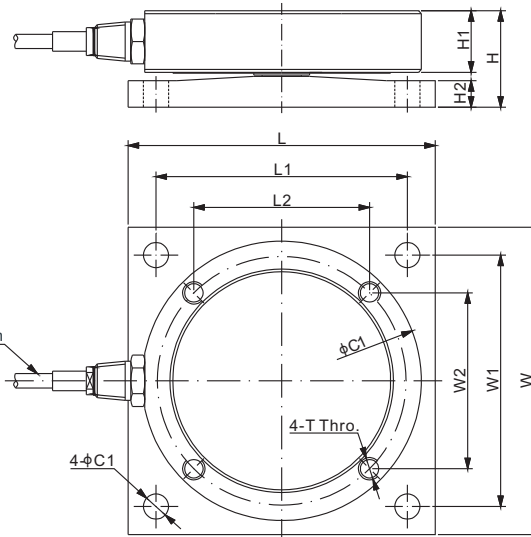

DIMENSIONS

RATED CAPACITY	C	C1	H	H1	H2	L	L1	L2	W	W1	W2	T
Klb/inches												
1-2.5	3.94	0.35	1.02	0.65	0.26	4.33	3.54	2.48	4.33	3.54	2.48	5/16-18 UNC-2B
5-10	4.72	0.35	1.40	0.93	0.33	5.12	4.33	3.00	5.12	4.33	3.00	3/8-16 UNC-2B
25-50	5.75	0.53	2.09	1.38	0.55	6.22	4.92	3.51	6.22	4.92	3.51	1/2-20 UNF-2B
100	8.43	0.83	3.07	1.97	0.83	9.84	8.11	4.98	9.84	8.11	4.98	3/4-16 UNF-2B
200	9.84	1.06	3.82	2.32	1.14	11.22	8.86	5.76	11.22	8.86	5.76	1-14 UNS-2B
t/mm												
0.5-1.2	100.0	9.0	26.0	16.5	6.5	110.0	90.0	62.9	110.0	90.0	62.9	M8×1.25
2.5-5	120.0	9.0	35.5	23.5	8.5	130.0	110.0	76.4	130.0	110.0	76.4	M10×1.5
12-25	146.0	13.5	53.0	35.0	14.0	158.0	125.0	89.1	158.0	125.0	89.1	M12×1.75
50	214.0	21.0	78.0	50.0	21.0	250.0	206.0	126.6	250.0	206.0	126.6	M18X2.5
100	250.0	27.0	97.0	59.0	29.0	285.0	225.0	146.4	285.0	225.0	146.4	M24X3

SPECIFICATIONS

Full Scale Output	3.0 mV/V ± 0.25%	Recommended Excitation	10V (15V Maximum)
Zero Balance	< ± 0.02 mV/V	Insulation Resistance	> 2 [50V DC] GΩ
Non-linearity	Cap. ≤ 1.2t/2.5Klb: < ± 0.05%;	Thermal Expansion / Contraction or Minor Misalignment	500kg - 5t / 1K - 10Klb: 2mm
	Cap.: 2.5t-12t/5K-25Klb: < ± 0.1% or < ± 0.3%		12t - 100t / 25Klb - 50t: 3mm
	Cap. ≥ 25t/50Klb: < ± 0.3%	Compensated Temperature Range	-10°C to 50°C / 14°F to 122°F
Repeatability	< ± 0.05%	Safe Overload	150% of full scale
Hysteresis Error	Cap. ≤ 1.2t/2.5Klb: < ± 0.05%; Cap.: 2.5t-12t/5K-25Klb: < ± 0.1% or < ± 0.3% Cap. ≥ 25t/50Klb: < ± 0.3%	Breaking Overload	300% of full scale
		Lift Protection	50% of full scale
		Side Protection	50% of full scale
Creep in 30 min.	< ± 0.05%	Seal Type / IP Rating	IP68 / IP69K
Input Resistance	700Ω ± 10	Cable Color Code	Exc+ Red Exc- Black
Output Resistance	700Ω ± 5		Sig+ Green Sig- White
Element Material	17-4PH Stainless Steel		Shield Bare

PART NUMBER		
Rated Capacity	Part No.	Weight (kg) Approx.
1Klb.....	363TSM1-1Klb	-
2.5Klb.....	363TSM1-2.5Klb.....	2.0
5Klb.....	363TSM1-5Klb.....	3.2
10Klb.....	363TSM1-10Klb.....	3.2
25Klb.....	363TSM1-25Klb.....	7.4
50Klb.....	363TSM1-50Klb.....	7.4
100Klb.....	363TSM1-100Klb.....	-
200Klb.....	363TSM1-200Klb.....	43.0

PART NUMBER		
Rated Capacity	Part No.	Weight (kg) Approx.
500kg.....	363TSM1-500kg	-
1.2t.....	363TSM1-1.2t.....	2.0
2.5t.....	363TSM1-2.5t.....	3.2
5t.....	363TSM1-5t.....	3.2
12t.....	363TSM1-12t.....	7.4
25t.....	363TSM1-25t.....	7.4
50t.....	363TSM1-50t.....	-
100t.....	363TSM1-100t.....	43.0

AVAILABLE OPTIONS

- Alloy Steel construction: 363THM1 (for 100Klb and 200Klb only)