

106MS-F-YZ

Stainless Steel

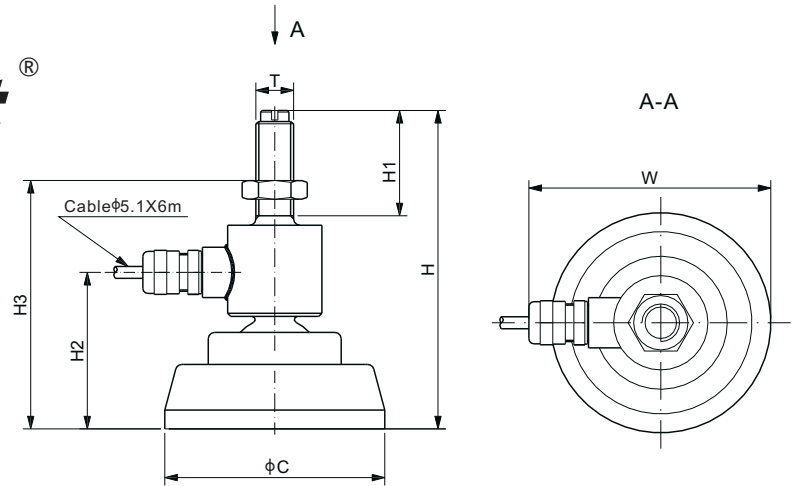

CE RoHS

DIMENSIONS

RATED CAPACITY	C	H	H1	H2	H3	W	T
t/mm							
0.5-1	70.0	101.3	33.5	51.8	76.0-99.0	77.0	M12
2	70.0	119.8	50.0	51.8	78.0-116.0	77.0	M16
5	80.0	132.8	55.0	59.8	87.0-127.0	82.0	M20
10	100.0	187.3	80.0	81.3	118.0-180.0	96.0	M24x2
Klb/inches							
1-2.5	2.76	3.99	1.32	1.96	2.99-3.90	3.03	1/2-20 UNF
5-10	3.15	5.23	2.17	2.35	3.43-5.00	3.23	3/4-16 UNF
20	3.94	7.37	3.15	3.20	4.65-7.09	3.78	1-14 UNS

SPECIFICATIONS

Full Scale Output	2.0 mV/V \pm 0.25%	Recommended Excitation	10V (15V Maximum)
Zero Balance	\pm 0.02 mV/V	Insulation Resistance	>2 [50V DC] G Ω
Non-linearity	Cap. \leq 2t: $< \pm$ 0.050%; Cap. > 2t: $< \pm$ 0.2%	Compensated Temperature Range	-10°C to 50°C / 14°F to 122°F
Repeatability	$< \pm$ 0.030%	Safe Overload	150% of full scale
Hysteresis Error	$< \pm$ 0.050%	Breaking Overload	300% of full scale
Creep in 30 min.	$< \pm$ 0.030%	Seal Type / IP Rating	Welded Seal / IP67
Input Resistance	380 Ω \pm 20	Cable Color Code	Exc+ Red Exc- Black
Output Resistance	350 Ω \pm 3		Sig+ Green Sig- White
Element Material	2Cr13 Stainless Steel		Shield Bare

PART NUMBER

Rated Capacity	Part No.	Weight (kg) Approx.
500kg	106MS-F-YZ-500kg	1.0
1t	106MS-F-YZ-1t	1.0
2t	106MS-F-YZ-2t	1.0
5t	106MS-F-YZ-5t	-
10t	106MS-F-YZ-10t	-
1Klb	106MS-F-YZ-1Klb	1.0
2.5Klb	106MS-F-YZ-2.5Klb	1.0
5Klb	106MS-F-YZ-5Klb	-
10Klb	106MS-F-YZ-10Klb	-
20Klb	106MS-F-YZ-20Klb	-

CANISTERS & DISKS