

OCSG Series

FEATURES

- Fast resolution switching
- 56mm 5 digits LED display
- Fixed hook
- HOLD function
- Tare In / Tare Out
- Unit switch: kg / lb
- Auto overload alarm at 100%F.S. +9e
- Auto power-off function



OPTION

- Wireless Scoreboard

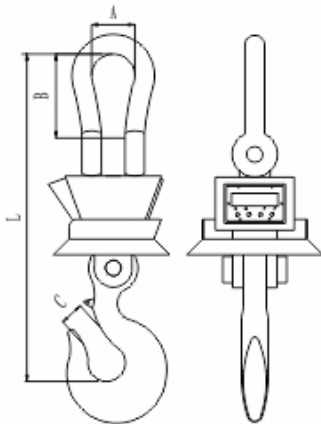

Model	OCSG2
Type	Heat Resistant
Accuracy Class	OIML III
Enclosure	Steel
Display	56mm LED
Capacity Available	10 / 20 / 30 / 40 / 60 Klb
Battery Life	100 Hours
High Quality Load Receptor	Alloy Steel
Shackle	H.D. Bow
Hook	H.D. Eye
High Capacity Rechargeable Battery	Yes 6V/10Ah
Infrared Remote Control	Yes

Rated Capacity	Division	A	B	C	L	N.W.	G.W.
10Klb	5 lb	105mm / 4.13"	140mm / 5.51"	70mm / 2.76"	850mm / 33.46"	60kg / 132.3 lb	59kg / 130.1 lb
20Klb	10 lb	140mm / 5.51"	160mm / 6.30"	75mm / 2.95"	900mm / 35.43"	80kg / 176.4 lb	69kg / 152.1 lb
30Klb	10 lb	150mm / 5.91"	180mm / 7.09"	80mm / 3.15"	950mm / 37.40"	95kg / 209.4 lb	85kg / 187.4 lb
40Klb	20 lb	165mm / 6.50"	215mm / 8.46"	90mm / 3.54"	1120mm / 44.09"	165kg / 363.8 lb	--
60Klb	20 lb	180mm / 7.09"	235mm / 9.25"	105mm / 4.13"	1350mm / 53.15"	395kg / 870.8 lb	--

*Dimensions and specifications are subject to change without notice.