

# 110RH-WL



## Alloy Steel; Wireless Tension Link; Patent Design



**TENSLINK™**

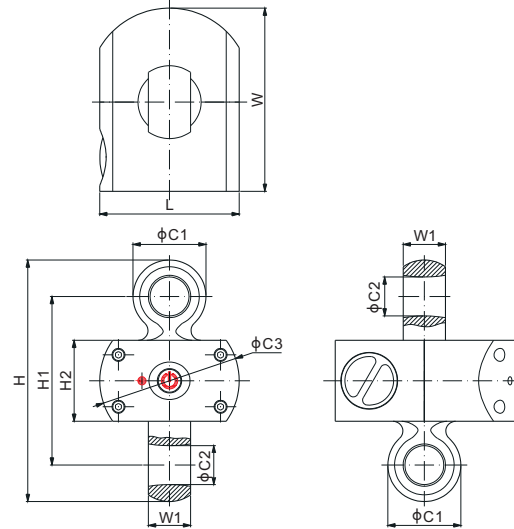

CE RoHS

\* Indicator to be ordered separately. Refer to Page 153 for details.

### DIMENSIONS

RATED CAPACITY	C1	C2	C3	H	H1	H2	L	W	W1	SUGGESTED SHACKLE
<b>t/mm</b>										
0.5; 1; 2	33.0	18.0	80.0	110.0	74.0	38.0	80.0	110.0	18.0	Crosby G-2130-2t or SBX-2t
3	35.0	21.0	80.0	129.0	88.0	38.0	80.0	110.0	25.0	Crosby G-2130-3.25t or SBX-3.25t
5	50.0	27.0	86.0	164.6	110.6	50.0	86.0	113.0	33.0	Crosby G-2130-6.5t or SBX-6.5t
10	63.0	37.0	86.0	205.0	135.0	50.0	86.0	125.0	41.0	Crosby G-2130-12t or SBX-12t
20	90.0	53.0	100.0	249.0	153.0	53.0	100.0	140.0	66.0	Crosby G-2130-25t or SBX-25t
30	87.0	44.0	100.0	248.0	150.0	50.0	100.0	152.0	58.0	Crosby G-2140-30t or TBX-30t
50	115.0	62.0	150.0	321.0	206.0	74.0	150.0	170.0	79.0	Crosby G-2140-55t or TBX-50t
<b>Klb/inches (conversion of above dimensions)</b>										
1; 2; 4	1.30	0.71	3.15	4.33	2.91	1.50	3.15	4.33	0.71	Crosby G-2130-2t or SBX-2t
5	1.38	0.83	3.15	5.08	3.46	1.50	3.15	4.33	0.98	Crosby G-2130-3.25t or SBX-3.25t
10	1.97	1.06	3.39	6.48	4.35	1.97	3.39	4.45	1.30	Crosby G-2130-6.5t or SBX-6.5t
20	2.48	1.46	3.39	8.07	5.31	1.97	3.39	4.92	1.61	Crosby G-2130-12t or SBX-12t
40	3.54	2.09	3.94	9.80	6.02	2.09	3.94	5.51	2.60	Crosby G-2130-25t or SBX-25t
60	3.43	1.73	3.94	9.76	5.91	1.97	3.94	5.98	2.28	Crosby G-2140-30t or TBX-30t
100	4.53	2.44	5.91	13.03	8.11	2.91	5.91	6.69	4.80	Crosby G-2140-55t or TBX-50t

### SPECIFICATIONS

Division	500kg: 0.1kg	<b>Max. Safety Load</b>	200% of full scale
	1t: 0.2kg	<b>Ultimate Load</b>	500% of full scale
	2t: 0.5kg	<b>Transmission Range</b>	Up to 75m
	5t: 1kg	<b>Operation Time</b>	Up to 100hours
	10t: 2kg	<b>Rechargeable Battery Type</b>	3 x AA Alkaline batteries
	20t: 5kg	<b>Operating Temperature</b>	-10°C to 50°C / 14°F to 122°F
Enclosure	30t, 50t: 10kg	<b>Operating Humidity</b>	<85% RH under 20°C[68°F]
	Alloy Steel, Powder Coating	<b>IP Rating</b>	IP67

### PART NUMBER

Rated Capacity	Frequency	Part No.	Self Weight Approx. (kg)
500kg.....	433 MHz.....	110RH-ST-500kg-WL01.....	0.6
	915 MHz.....	110RH-ST-500kg-WL02.....	0.6
1t.....	433 MHz.....	110RH-ST-1t-WL01.....	0.6
	915 MHz.....	110RH-ST-1t-WL02.....	0.6
2t.....	433 MHz.....	110RH-ST-2t-WL01.....	0.6
	915 MHz.....	110RH-ST-2t-WL02.....	0.6
3t.....	433 MHz.....	110RH-ST-3t-WL01.....	1.0
	915 MHz.....	110RH-ST-3t-WL02.....	1.0
5t.....	433 MHz.....	110RH-ST-5t-WL01.....	1.4
	915 MHz.....	110RH-ST-5t-WL02.....	1.4

### PART NUMBER

Rated Capacity	Frequency	Part No.	Self Weight Approx. (kg)
10t.....	433 MHz.....	110RH-ST-10t-WL01.....	2.3
	915 MHz.....	110RH-ST-10t-WL02.....	2.3
20t.....	433 MHz.....	110RH-ST-20t-WL01.....	4.7
	915 MHz.....	110RH-ST-20t-WL02.....	4.7
30t.....	433 MHz.....	110RH-30t-WL01.....	5.5
	915 MHz.....	110RH-30t-WL02.....	5.5
50t.....	433 MHz.....	110RH-50t-WL01.....	19.2
	915 MHz.....	110RH-50t-WL02.....	19.2