

563YSMT



Stainless Steel

SINGLE ENDED BEAMS



PIN to be ordered separately.

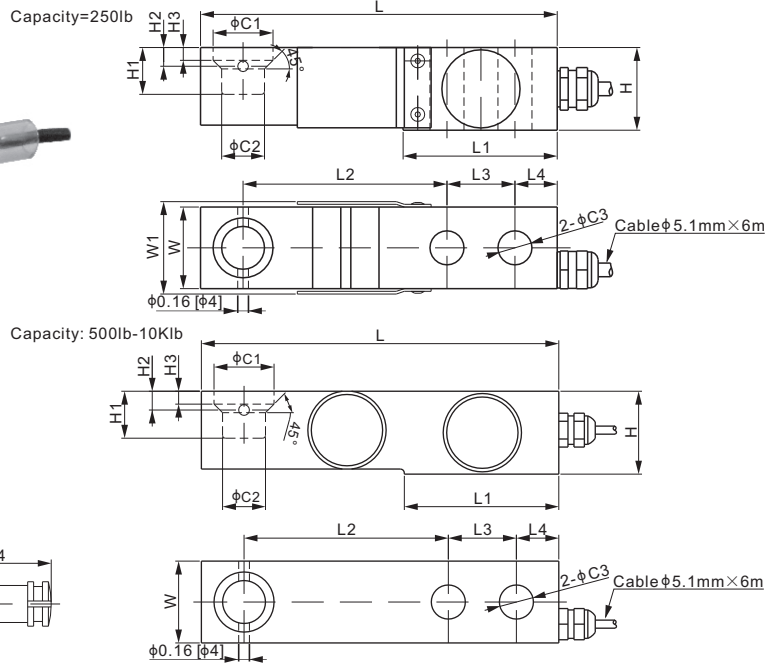

DIMENSIONS

RATED CAPACITY	C1	C2	C3	C4	H	H1	H2	H3	H4	L	L1	L2	L3	L4	W	W1
lb/inches																
250	0.88	0.63	0.50	0.59	1.22	0.69	0.28	0.19	1.5	5.25	2.27	3.00	1.00	0.62	1.20	1.38
500-4,000	0.88	0.63	0.50	0.59	1.22	0.69	0.28	0.19	1.5	5.25	2.27	3.00	1.00	0.62	1.20	-
5,000	0.88	0.63	0.50	-	1.40	0.92	0.47	0.38	-	5.38	2.28	3.00	1.00	0.62	1.46	-
10,000	1.38	0.88	0.75	-	1.68	1.17	0.59	0.46	-	6.87	3.34	3.75	1.50	0.75	1.68	-
kg/mm (conversion of above dimensions)																
113.4	22.4	16.0	12.7	15.0	30.9	17.5	7.0	4.8	38.1	133.3	57.6	76.2	25.4	15.8	30.5	35.0
226.8-1,814.4	22.4	16.0	12.7	15.0	30.9	17.5	7.0	4.8	38.1	133.3	57.6	76.2	25.4	15.8	30.5	-
2,268.0	22.4	16.0	12.7	-	35.5	23.4	11.9	9.7	-	136.7	57.9	76.2	25.4	15.8	37.1	-
4,535.9	35.1	22.4	19.1	-	42.6	29.7	15.0	11.8	-	174.5	84.8	95.3	38.1	19.1	42.7	-

SPECIFICATIONS

Full Scale Output	2.0 mV/V \pm 0.25%	Recommended Excitation	10V (15V Maximum)
Zero Balance	\pm 0.02 mV/V	Insulation Resistance	>2 [50V DC] G Ω
Non-linearity	< \pm 0.023%	Compensated Temperature Range	-10°C to 50°C / 14°F to 122°F
Repeatability	< \pm 0.017%	Safe Overload	150% of full scale
Hysteresis Error	< \pm 0.023%	Breaking Overload	300% of full scale
Creep in 30 min.	< \pm 0.023%	Seal Type / IP Rating	Welded Seal / IP68
Input Resistance	350 Ω \pm 7	Cable Color Code	Exc+ Red Exc- Black Sig+ Green Sig- White Shield Bare
Output Resistance	350 Ω \pm 3		
Element Material	17-4PH Stainless Steel		

PART NUMBER

Load Cell	Part No.	Shipping Weight (kg) Approx.
Rated Capacity		
250lb.....	563YSMT-250lb.....	1.0
500lb.....	563YSMT-500lb.....	1.0
1.25Klb.....	563YSMT-1.25Klb.....	1.0
2.5Klb.....	563YSMT-2.5Klb.....	1.0
4Klb.....	563YSMT-4Klb.....	1.0
5Klb.....	563YSMT-5Klb.....	1.3
10Klb.....	563YSMT-10Klb.....	2.0

Hardware

Hardware	Load Cell Capacity	Part No.	Shipping Weight (kg)
Pin.....	500lb-4Klb.....	563YSMT-(0.5-4)Klb-PIN.....	0.1

INTERCHANGEABLE PRODUCTS

Manufacturer	Model
Coti Global.....	CG-745
HBM.....	THC
Mettler-Toledo.....	MT0744*
Mettler-Toledo.....	MT0745A
Rice Lake.....	RL30745

* MT0744 is environmentally sealed and interchangeable with ANYLOAD 563YSMT-250lb

- 250lb-2.5Klb: NTEP 1:5 000 Class III, Single Cell;
NTEP 1:9 500 Class III, Multiple Cell
- 4Klb-10Klb: NTEP 1:6 000 Class III, Single Cell;
NTEP 1:10 000 Class III, Multiple Cell
- 1.25Klb-5Klb: OIML MAA C5, Y=26 000;
- 10Klb: OIML MAA C6, Y=8 500