

102BH

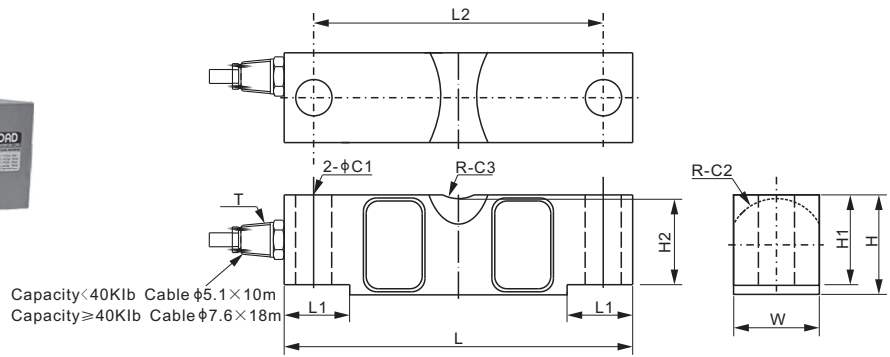

Alloy Steel



DOUBLE ENDED BEAMS

DIMENSIONS

RATED CAPACITY	C1	C2	C3	H	H1	H2	L	L1	L2	W	T
Klb/inches											
10-25	0.68	0.90	0.75	1.94	1.70	1.63	7.75	1.38	6.50	1.69	1/4-18 NPT
40	0.81	1.12	0.98	2.44	2.10	2.03	10.25	1.93	8.50	1.94	1/2-14 NPT
50-75	1.06	1.38	0.98	2.94	2.65	2.53	10.25	1.93	8.50	2.44	1/2-14 NPT
SE100	1.06	1.38	0.98	3.44	2.65	2.53	10.25	1.93	8.50	2.44	1/2-14 NPT
100-125	1.62	1.80	1.50	3.86	3.43	3.30	15.25	3.13	12.75	2.90	1/2-14 NPT
200	1.62	2.37	2.00	5.80	5.12	4.44	19.25	4.00	15.25	3.80	1/2-14 NPT
300	2.12	4.00	2.50	5.80	5.12	4.44	22.00	5.00	17.00	5.80	1/2-14 NPT
400	2.12	5.00	3.00	5.80	5.12	4.44	22.00	5.00	17.00	5.80	1/2-14 NPT
t/mm											
5-15	17.3	22.9	19.1	49.3	43.2	41.5	196.9	35.1	165.1	42.9	1/4-18 NPT
20	20.5	28.4	25.0	62.0	53.4	51.6	260.4	49.0	216.0	49.3	1/4-18 NPT
25-35	27.0	35.0	25.0	74.6	67.2	64.3	260.4	49.0	216.0	62.0	1/2-14 NPT
50	41.2	45.7	38.1	98.0	87.1	83.8	387.4	79.5	323.9	73.7	1/2-14 NPT

SPECIFICATIONS

Full Scale Output	3.0 mV/V $\pm 0.25\%$	Recommended Excitation	10V (15V Maximum)
Zero Balance	± 0.02 mV/V	Insulation Resistance	>2 [50V DC] G Ω
Non-linearity	$< \pm 0.023\%$	Compensated Temperature Range	-10°C to 50°C / 14°F to 122°F
Repeatability	$< \pm 0.017\%$	Safe Overload	150% of full scale
Hysteresis Error	$< \pm 0.023\%$	Breaking Overload	300% of full scale
Creep in 30 min.	$< \pm 0.023\%$	Seal Type / IP Rating	Environmentally Sealed / IP67
Input Resistance	700 Ω ± 10	Cable Color Code	Exc+ Red Exc- Black
Output Resistance	700 Ω ± 5		Sig+ Green Sig- White
Element Material	Alloy Steel, Nickel Plated		Shield Bare

PART NUMBER

Rated Capacity	Part No.	Shipping Weight (kg) Approx.
10Klb.....	102BH-10Klb.....	2.9
20Klb.....	102BH-20Klb.....	3.0
25Klb.....	102BH-25Klb.....	3.0
40Klb.....	102BH-40Klb.....	7.0
50Klb.....	102BH-50Klb.....	9.0
60Klb.....	102BH-60Klb.....	9.0
75Klb.....	102BH-75Klb.....	9.0
SE100Klb.....	102BH-SE100Klb.....	10.0
100Klb.....	102BH-100Klb.....	20.5
125Klb.....	102BH-125Klb.....	20.5
200Klb.....	102BH-200Klb.....	47.0
300Klb.....	102BH-300Klb.....	75.0
400Klb.....	102BH-400Klb.....	80.5
5t.....	102BH-5t.....	3.0
10t.....	102BH-10t.....	3.0
15t.....	102BH-15t.....	3.0
20t.....	102BH-20t.....	7.0
25t.....	102BH-25t.....	9.0
30t.....	102BH-30t.....	9.0
35t.....	102BH-35t.....	9.0
50t.....	102BH-50t.....	20.5

Lightning Protection Version:

60Klb.....	102BH-60Klb-02.....	9.0
75Klb.....	102BH-75Klb-02.....	9.0

SE refers to small envelope

WEIGH MODULE

Model	Page
102BHM1.....	127

INTERCHANGEABLE PRODUCTS

Manufacturer	Model
Coti Global.....	CG-58
Rice Lake.....	RL75058
Vishay Celtron.....	CLB
Vishay Revere Transducers.....	5303
Vishay Sensortronics.....	65058A*
Vishay TedeA-Huntleigh.....	4158

* Sensortronics 65058A has SE50Klb and 50Klb.

25Klb-125Klb: NTEP 1:10 000 Class III L, Multiple Cell

11t-55t: OIML MAA C3, Y=7500