

Floor Scale Ramp

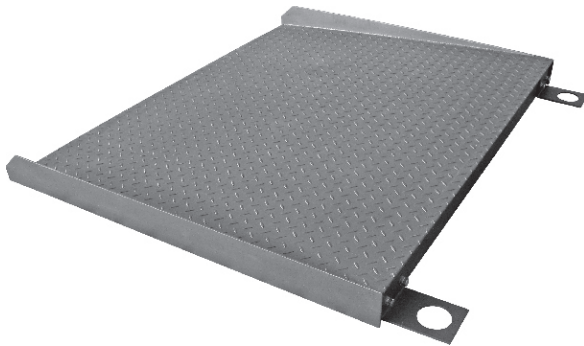

Features:

- Mild steel construction
- Rugged checker plate surface
- Surface coated with high quality industrial paint
- Includes removable L-shape base mounting plates with connecting nuts and bolts

RAMP Includes:

- 1 piece x ramp
- 2 pieces x L-shape base mounting plates (item code: BG-P80)
- 4 pieces x M10X30mm nuts and bolts

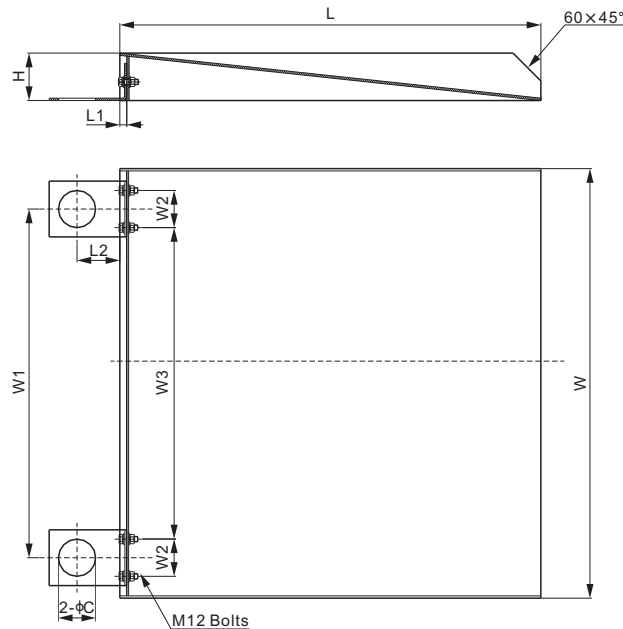

DIMENSIONS

PART NUMBER	C	H	L	L1	L2	W	W1	W2	W3	Shipping Weight (kg)
inches										
RAMP3x3	3.15	4.02	35.67	0.59	3.62	36.38	29.53	3.15	26.38	50.9
RAMP3x4	3.15	4.02	47.76	0.59	3.62	36.38	29.53	3.15	26.38	-
RAMP4x3	3.15	4.02	35.67	0.59	3.62	48.39	41.50	3.15	38.35	61
RAMP4x4	3.15	4.02	47.76	0.59	3.62	48.39	41.50	3.15	38.35	81
RAMP5x3	3.15	4.02	35.67	0.59	3.62	59.45	52.56	3.15	49.41	-
RAMP5x4	3.15	4.02	47.76	0.59	3.62	59.45	51.18	3.15	48.03	103
mm (conversion of above dimensions)										
RAMP3x3	80	102	906	15	92	924	750	80	670	50.9
RAMP3x4	80	102	1213	15	92	924	750	80	670	-
RAMP4x3	80	102	906	15	92	1229	1054	80	974	61
RAMP4x4	80	102	1213	15	92	1229	1054	80	974	81
RAMP5x3	80	102	906	15	92	1510	1335	80	1255	-
RAMP5x4	80	102	1213	15	92	1510	1300	80	1220	103