

## Stainless Steel, Wireless Tension Link

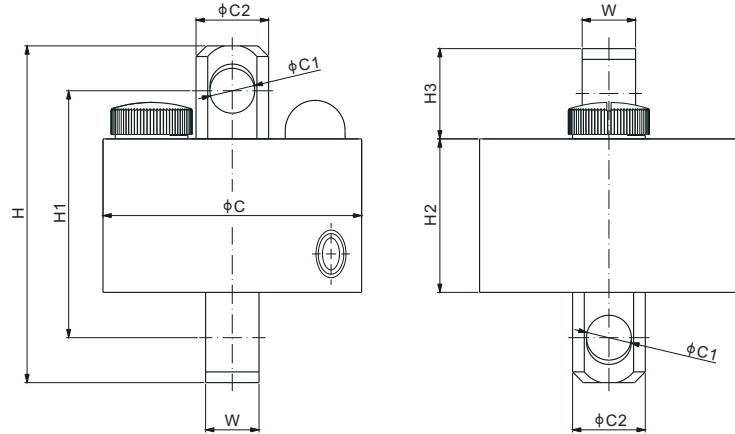

### DIMENSIONS

RATED CAPACITY	C	C1	C2	H	H1	H2	H3	W	SUGGESTED SHACKLE
<b>t/mm</b>									
1	121	13	25	130.4	104	70	30.7	15.5	TBX-2t
2.5	121	15	25	130.4	104	70	30.7	17	TBX-2.5t
5	121	21	34	157.5	115.5	71.8	43.5	25	TBX-5t or RBXS-5t
10	133	31.5	50	197	141.5	72	63.3	40	TBX-12.5t
20	159	42	68	245	171	72.5	87	50	TBX-21t
30	205	45	80	295	206	92	99.5	52	TBX-30t
50	205	63	109	368	250	105	130	79	TBX-50t
100	273	90	152	496	332	146.5	174	112	TBX-110t
<b>Klb/inches (conversion of above dimensions)</b>									
2	4.76	0.51	0.98	5.13	4.10	2.76	1.21	0.61	TBX-2t
5	4.76	0.59	0.98	5.13	4.10	2.76	1.21	0.67	TBX-2.5t
10	4.76	0.83	1.34	6.20	4.55	2.83	1.71	0.98	TBX-5t or RBXS-5t
20	5.24	1.24	1.97	7.76	5.57	2.83	2.49	1.57	TBX-12.5t
40	6.26	1.65	2.68	9.65	6.73	2.85	3.43	1.97	TBX-21t
60	8.07	1.77	3.15	11.61	8.11	3.62	3.92	2.05	TBX-30t
100	8.07	2.48	4.29	14.49	9.84	4.13	5.12	3.11	TBX-50t
200	10.75	3.54	5.98	19.53	13.07	5.77	6.85	4.41	TBX-110t

### SPECIFICATIONS

<b>Division</b>	1t-10t: 1:5 000	<b>Transmission Range</b>	Up to 30m
	20t: 1:4 000	<b>Operation Time</b>	100 hours
	30t: 1:3 000	<b>Rechargeable Battery Type</b>	3 x AA Alkaline batteries
	50t-100t: 1:5 000	<b>Operating Temp.</b>	-10°C to 40°C / 14°F to 104°F
<b>Max. Safety Load</b>	200%F.S.	<b>Operating Humidity</b>	<85% RH under 20°C [68°F]
<b>Ultimate Load</b>	400%F.S.	<b>IP Rating</b>	IP68 / 69K
<b>Enclosure</b>	Stainless Steel Casting		

### PART NUMBER

Rated Capacity	Frequency	Part No.	Self Weight (kg) (Batteries included)
1t	433 Mhz	110ES-1t-WL01-HP	1.7
	915 Mhz	110ES-1t-WL02-HP	1.7
2.5t	433 Mhz	110ES-2.5t-WL01-HP	1.7
	915 Mhz	110ES-2.5t-WL02-HP	1.7
5t	433 Mhz	110ES-5t-WL01-HP	2.1
	915 Mhz	110ES-5t-WL02-HP	2.1
10t	433 Mhz	110ES-10t-WL01-HP	3.5
	915 Mhz	110ES-10t-WL02-HP	3.5
20t	433 Mhz	110ES-20t-WL01-HP	6.6
	915 Mhz	110ES-20t-WL02-HP	6.6
30t	433 Mhz	110ES-30t-WL01-HP	10.5
	915 Mhz	110ES-30t-WL02-HP	10.5
50t	433 Mhz	110ES-50t-WL01-HP	21
	915 Mhz	110ES-50t-WL02-HP	21
100t	433 Mhz	110ES-100t-WL01-HP	53
	915 Mhz	110ES-100t-WL02-HP	53