

# ANYLOAD

## A2A Water Tight Amplifier



1.1: Installation: Single point fixing / All round fixing (out-door)

1.2: Connection Diagram:

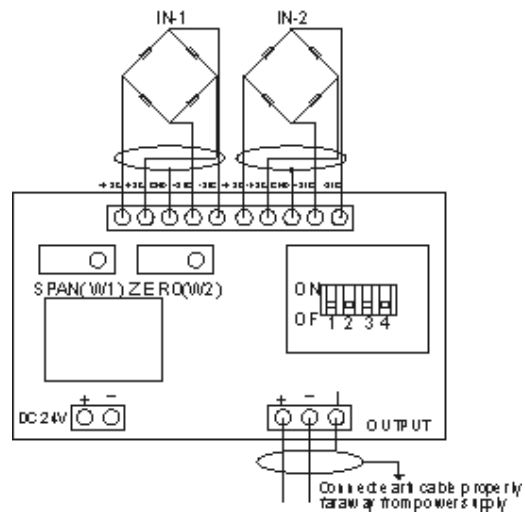

Red: EXC+  
Black:EXC-  
Green:SIG+  
White:SIG-

# ANYLOAD

## 1.3: Turn Switch:

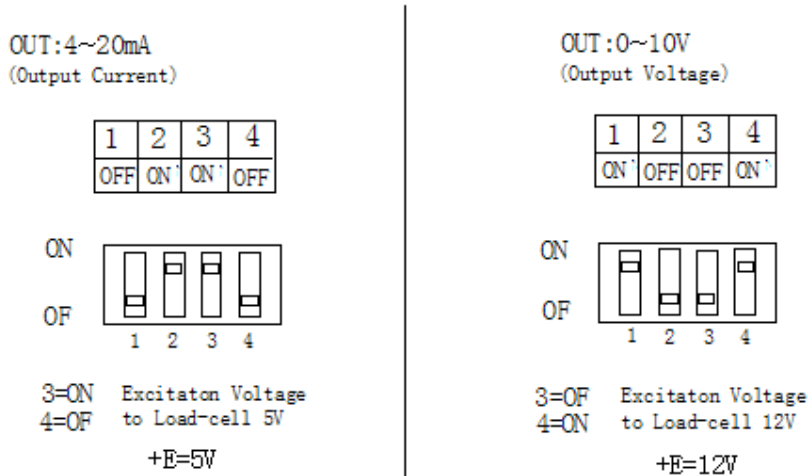

Shift Excitation voltage according to the sensitivity of load cell, the bigger excitation voltage is, the more output is

## 1.4: Specification:

Power Supply: DC24V±20%、<3W  
Input Range: 0~30 mV  
Output Signal: 0~10V / 4~20mA (adjustable±20%)

## 1.5: Max. Overload Current Protection:

Power Voltage > DC30V, 2.5A  
Output Signal > 20V or >40mA

## 1.6: Commissioning:

**ZERO** Zero setting (Self-weight shall not exceed 30% of full capacity, adjust **ZERO** variable resistor to a output of 0V or 4mA)

**SPAN** Capacity setting (Add standard load of full capacity to load-cell, adjust **SPAN** variable resistor to a output of 10V or 20mA)

Remark: suggest to repeat the adjustment 3 times; added load shall be 20% over the full capacity

## 1.7: Parallel Deviation Rectification:

1/variable resistor to the same output when two load-cells have the same load.

(Skip the above when there is only one load-cell input.)

2/ Calibrate three times, to make sure the data is repeatable.

3/ If no full capacity load is available, since the load cell and amplifier have their own linearity, calibrate with part of capacity weight would be acceptable, but remember the lower rate of weight/capacity is, the lower accuracy is.