

110RH-WL, 805HP-WL



Multiple Patents



* Paint color may vary

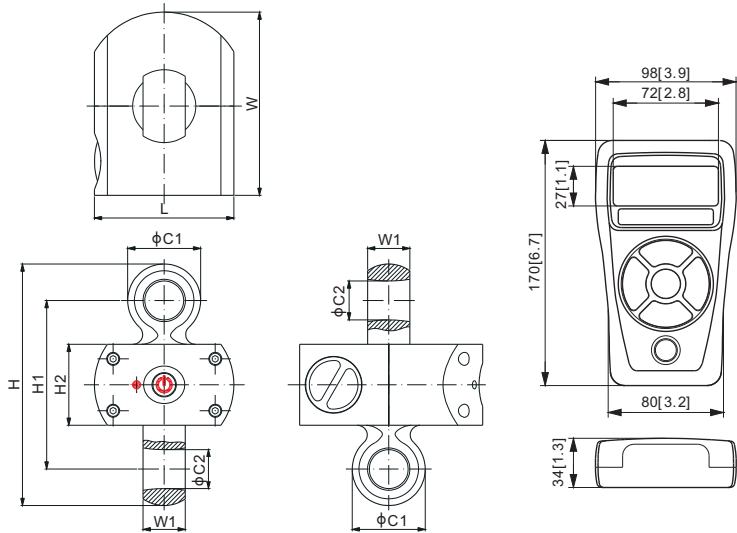

RATED CAPACITY	C1	C2	H	H1	H2	L	W	W1	DIVISION	SUGGESTED SHACKLE
t/mm										
0.5; 1; 2	33.0	18.0	110.0	74.0	38.0	80.0	110.0	18.0	0.1kg/0.2kg/0.5kg	Crosby G-2130-2t or SBX-2t
5	50.0	27.0	164.6	110.6	50.0	86.0	113.0	33.0	1kg	Crosby G-2130-6.5t or SBX-6.5t
10	63.0	37.0	205.0	135.0	50.0	86.0	125.0	41.0	2kg	Crosby G-2130-12t or SBX-12t
20	90.0	53.0	249.0	153.0	53.0	100.0	140.0	66.0	5kg	Crosby G-2130-25t or SBX-25t
30	87.0	44.0	248.0	150.0	50.0	100.0	152.0	58.0	10kg	Crosby G-2140-30t or TBX-30t
50	115.0	62.0	321.0	206.0	74.0	150.0	170.0	79.0	10kg	Crosby G-2140-55t or TBX-50t
Klb/inches (conversion of above dimensions)										
1.1; 2.2; 4.4	1.30	0.71	4.33	2.91	1.50	3.15	4.33	0.71	0.2lb/0.5lb/1lb	Crosby G-2130-2t or SBX-2t
11.0	1.97	1.06	6.48	4.35	1.97	3.39	4.45	1.30	2lb	Crosby G-2130-6.5t or SBX-6.5t
22.0	2.48	1.46	8.07	5.31	1.97	3.39	4.92	1.61	5lb	Crosby G-2130-12t or SBX-12t
44.1	3.54	2.09	9.80	6.02	2.09	3.94	5.51	2.60	10lb	Crosby G-2130-25t or SBX-25t
66.1	3.43	1.73	9.76	5.91	1.97	3.94	5.98	2.28	20lb	Crosby G-2140-30t or TBX-30t
110.2	4.53	2.44	13.03	8.11	2.91	5.91	6.69	4.80	20lb	Crosby G-2140-55t or TBX-50t

Load Cell Specifications	
Enclosure	Alloy Steel, Powder Coating
Max. Safety Load	200% of full scale
Ultimate Load	500% of full scale
Wireless Distance (adjustable)	30m (Power 1.26mW)
	40m (Power 1.56mW)
	55m (Power 3.13mW)
	75m (Power 6.25mW)
Operation Time	Up to 100 hours
Battery Type	3 × AA Alkaline batteries
Operating Temperature	-10°C to 50°C / 14°F to 122°F
IP Rating	IP67

Indicator Specifications	
Tare range	100% Full Scale
Enclosure Material	ABS
Units of Measurement	kg, g, t, lb, Klb, N, kN, oz, user-defined unit
Working Temperature	-10°C to 50°C / 14°F to 122°F
Dimensions	170mm × 98mm × 34mm
	6.7in × 3.9in × 1.34in
Display Type	LCD with backlight
Display Digits	6 digits
Digit Height	16.8mm / 0.66in
Display Dimensions	72mm × 27mm / 2.8in × 1.1in
Max. Power Consumption	6.25mW
Power Supply	3 × AA Alkaline batteries
Operation Time	Up to 100 hours
IP Rating	IP65

PART NUMBER			
110RH-WL			
Rated Capacity	Frequency	Part No.	Self Weight Approx. (kg)
0.5t	433 MHz	110RH-ST-0.5t-WL01	0.6
	915 MHz	110RH-ST-0.5t-WL02	0.6
1t	433 MHz	110RH-ST-1t-WL01	0.6
	915 MHz	110RH-ST-1t-WL02	0.6
2t	433 MHz	110RH-ST-2t-WL01	0.6
	915 MHz	110RH-ST-2t-WL02	0.6
5t	433 MHz	110RH-ST-5t-WL01	1.4
	915 MHz	110RH-ST-5t-WL02	1.4
10t	433 MHz	110RH-ST-10t-WL01	2.3
	915 MHz	110RH-ST-10t-WL02	2.3
20t	433 MHz	110RH-ST-20t-WL01	4.7
	915 MHz	110RH-ST-20t-WL02	4.7
30t	433 MHz	110RH-30t-WL01	5.5
	915 MHz	110RH-30t-WL02	5.5
50t	433 MHz	110RH-50t-WL01	12.5
	915 Mhz	110RH-50t-WL02	12.5

PART NUMBER		
805HP-WL		
Part No.	Frequency	Weight (kg)
805HP-WL01	433 MHz	0.36
805HP-WL02	915 MHz	0.36