

# 651TA; 651TAUN

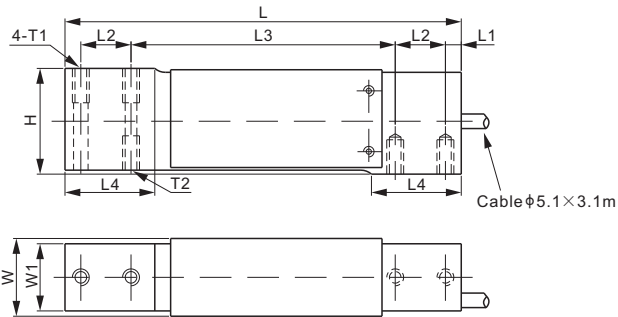

## Aluminum



## RoHS

### DIMENSIONS

RATED CAPACITY	H	L	L1	L2	L3	L4	W	W1	T1	T2
<b>651TA:</b>										
<b>kg/mm</b>										
10-200	40.0	150.0	6.0	19.0	100.0	34.0	29.4	25.4	M6 Depth13	M6 Depth13
<b>lb/inches</b> (conversion of above dimensions)										
22.05-440.92	1.57	5.91	0.23	0.75	3.94	1.34	1.16	1.00	M6 Depth0.51	M6 Depth0.51
<b>651TAUN:</b>										
<b>kg/mm</b>										
10-200	40.0	150.0	6.0	19.0	100.0	34.0	29.4	25.4	1/4-20 UNC Depth13	1/4-28 UNF Depth13
<b>lb/inches</b> (conversion of above dimensions)										
22.05-440.92	1.57	5.91	0.23	0.75	3.94	1.34	1.16	1.00	1/4-20 UNC Depth0.51	1/4-28 UNF Depth0.51

### SPECIFICATIONS

<b>Full Scale Output</b>	2.0 ± 10% mV/V	<b>Recommended Excitation</b>	10V (15V Maximum)
<b>Zero Balance</b>	± 0.02 mV/V	<b>Reference Max. Platform Size</b>	450×500 mm
<b>Non-linearity</b>	< ± 0.017%	<b>Insulation Resistance</b>	>2 [ 50V DC ] GΩ
<b>Repeatability</b>	< ± 0.017%	<b>Nominal Temperature Range</b>	-10°C to 40°C / 14°F to 104°F
<b>Hysteresis Error</b>	< ± 0.017%	<b>Safe Overload</b>	150% of full scale
<b>Creep in 30 min.</b>	< ± 0.023%	<b>Breaking Overload</b>	300% of full scale
<b>Input Resistance</b>	415Ω ± 15	<b>Seal Type / IP Rating</b>	Environmentally Sealed, Potted / IP67
<b>Output Resistance</b>	350Ω ± 3	<b>Cable Color Code</b>	Exc+ Red    Exc- Black Sig+ Green    Sig- White    Shield Bare
<b>Element Material</b>	Aluminum		

### PART NUMBER

Rated Capacity	Part No.	Shipping Weight (kg) Approx.
10kg.....	651TA-10kg.....	0.5
	651TAUN-10kg.....	0.5
15kg.....	651TA-15kg.....	0.5
	651TAUN-15kg.....	0.5
20kg.....	651TA-20kg.....	0.5
	651TAUN-20kg.....	0.5
30kg.....	651TA-30kg.....	0.5
	651TAUN-30kg.....	0.5
50kg.....	651TA-50kg.....	0.5
	651TAUN-50kg.....	0.5
75kg.....	651TA-75kg.....	0.5
	651TAUN-75kg.....	0.5
100kg.....	651TA-100kg.....	0.5
	651TAUN-100kg.....	0.5
200kg.....	651TA-200kg.....	0.5
	651TAUN-200kg.....	0.5

### INTERCHANGEABLE PRODUCTS

Manufacturer	Model
<b>651TAUN</b>	
Coti Global.....	CG-40
Mettler-Toledo.....	MT1041
Rice Lake.....	RL1040
Vishay Celtron.....	LOC
Vishay Tedeo-Huntleigh.....	1040
Vishay Tedeo-Huntleigh.....	1041

SINGLE POINTS