

# 563YSMT

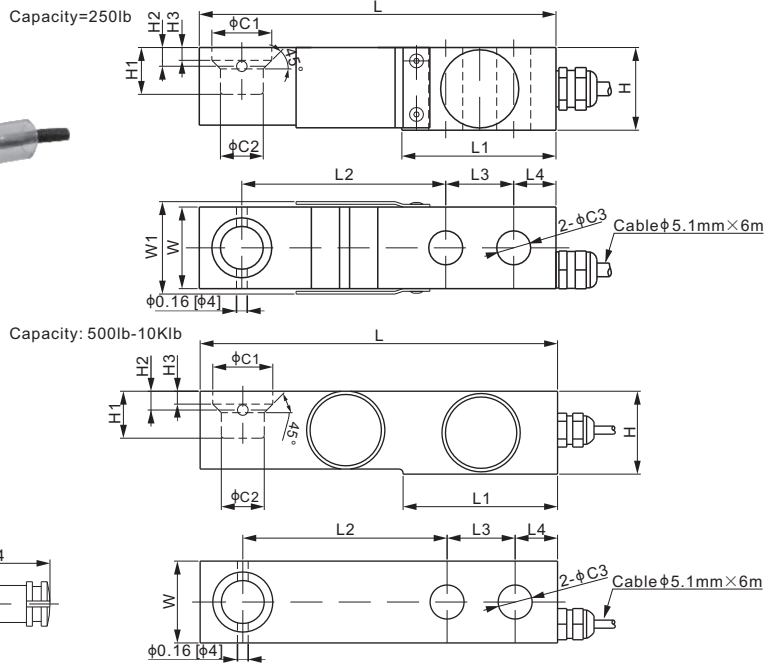

## Stainless Steel

SINGLE ENDED BEAMS



PIN to be ordered separately.

### DIMENSIONS

RATED CAPACITY	C1	C2	C3	C4	H	H1	H2	H3	H4	L	L1	L2	L3	L4	W	W1
<b>lb/inches</b>																
250	0.88	0.63	0.50	0.59	1.22	0.69	0.28	0.19	1.5	5.25	2.27	3.00	1.00	0.62	1.20	1.38
500-4,000	0.88	0.63	0.50	0.59	1.22	0.69	0.28	0.19	1.5	5.25	2.27	3.00	1.00	0.62	1.20	-
5,000	0.88	0.63	0.50	-	1.40	0.92	0.47	0.38	-	5.38	2.28	3.00	1.00	0.62	1.46	-
10,000	1.38	0.88	0.75	-	1.68	1.17	0.59	0.46	-	6.87	3.34	3.75	1.50	0.75	1.68	-
<b>kg/mm</b> (conversion of above dimensions)																
113.4	22.4	16.0	12.7	15.0	30.9	17.5	7.0	4.8	38.1	133.3	57.6	76.2	25.4	15.8	30.5	35.0
226.8-1,814.4	22.4	16.0	12.7	15.0	30.9	17.5	7.0	4.8	38.1	133.3	57.6	76.2	25.4	15.8	30.5	-
2,268.0	22.4	16.0	12.7	-	35.5	23.4	11.9	9.7	-	136.7	57.9	76.2	25.4	15.8	37.1	-
4,535.9	35.1	22.4	19.1	-	42.6	29.7	15.0	11.8	-	174.5	84.8	95.3	38.1	19.1	42.7	-

### SPECIFICATIONS

Full Scale Output	2.0 ± 0.25% mV/V	Recommended Excitation	10V (15V Maximum)
Zero Balance	± 0.02 mV/V	Insulation Resistance	> 2 [ 50V DC ] GΩ
Non-linearity	< ± 0.023%	Compensated Temperature Range	-10°C to 50°C / 14°F to 122°F
Repeatability	< ± 0.017%	Safe Overload	150% of full scale
Hysteresis Error	< ± 0.023%	Breaking Overload	300% of full scale
Creep in 30 min.	< ± 0.023%	Seal Type / IP Rating	Welded Seal / IP68
Input Resistance	350 Ω ± 7	Cable Color Code	Exc+ Red      Exc- Black
Output Resistance	350 Ω ± 3		Sig+ Green    Sig- White
Element Material	17-4PH Stainless Steel		Shield Bare

### PART NUMBER

Load Cell	Rated Capacity	Part No.	Shipping Weight (kg) Approx.
	250lb	563YSMT-250lb	1.0
	500lb	563YSMT-500lb	1.0
	1.25Klb	563YSMT-1.25Klb	1.0
	2.5Klb	563YSMT-2.5Klb	1.0
	4Klb	563YSMT-4Klb	1.0
	5Klb	563YSMT-5Klb	1.3
	10Klb	563YSMT-10Klb	2.0

### Hardware

Hardware	Load Cell Capacity	Part No.	Shipping Weight (kg)
Pin	.....500lb-4Klb	.....563YSMT-(0.5-4)Klb-PIN	.....0.1

### INTERCHANGEABLE PRODUCTS

Manufacturer	Model
Coti Global	CG-745
HBM	THC
Mettler-Toledo	MT0744*
Mettler-Toledo	MT0745
Rice Lake	RL30745

\* MT0744 is environmentally sealed and interchangeable with ANYLOAD 563YSMT-250lb

10Klb: OIML MAA C6, Y=85 000

