

106PS; 106PS20

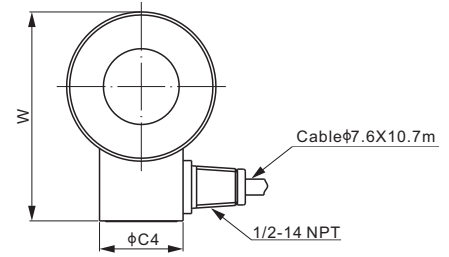

Stainless Steel

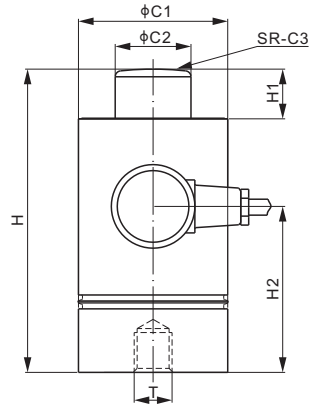

CE RoHS

DIMENSIONS

RATED CAPACITY	C1	C2	C3	C4	H	H1	H2	W	T
Klb/inches									
50	2.95	1.50	6.00	1.65	6.00	0.98	3.28	4.13	3/4-16 UNF Depth 0.59
100	3.94	1.75	12.00	1.65	8.50	1.10	4.76	5.12	3/4-16 UNF Depth 0.59
kg/mm (conversion of above dimensions)									
22,679.6	75	38.1	152.4	42	152.4	25	83.4	105	3/4-16 UNF Depth 15
45,359.2	100	44.5	304.8	42	215.9	28	121	130	3/4-16 UNF Depth 15

SPECIFICATIONS

Full Scale Output	106PS: 3.0 ± 0.1% mV/V	Recommended Excitation	10V (15V Maximum)
	106PS20: 2.0 ± 0.1% mV/V		Insulation Resistance
Zero Balance	± 0.02 mV/V	Compensated Temperature Range	-10°C to 50°C / 14°F to 122°F
Non-linearity	< ± 0.030%	Safe Overload	150% of full scale
Repeatability	< ± 0.017%	Breaking Overload	300% of full scale
Hysteresis Error	< ± 0.017%	Seal Type / IP Rating	Welded Seal / IP68
Creep in 30 min.	< ± 0.030%	Cable Color Code	Exc+ Red Exc- Black
Input Resistance	350 Ω ± 3.5		Sig+ Green Sig- White
Output Resistance	350 Ω ± 3.5		Shield Bare
Element Material	2Cr13 Stainless Steel		

PART NUMBER

Rated Capacity	Part No.	Shipping Weight (kg) Approx.
50Klb.....	106PS-50Klb-YZ.....	3.8
	106PS20-50Klb-YZ.....	3.8
100Klb.....	106PS-100Klb-YZ.....	7.1
	106PS20-100Klb-YZ.....	7.1

INTERCHANGEABLE PRODUCTS

Manufacturer	Model
106PS	
Coti Global.....	CG-93
Vishay Revere Transducers.....	93
106PS20	
Coti Global.....	CG-92
Vishay Revere Transducers.....	92

CANISTERS & DISKS