

OCSM Series

FEATURES

- Fast resolution switching
- 30mm 5 digits LED display for OCSM1
- 30mm 5 digits LCD display for OCSM2
- Rotatable hook
- Idle mode to maximize the battery life
- HOLD function
- Tare In / Tare Out
- Unit switch: kg / lb
- Auto overload alarm at 100%F.S. +9e
- Auto power-off function



OPTION

- Wireless Scoreboard

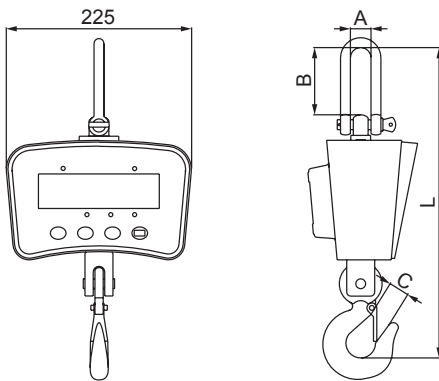

Model	OCSM1	OCSM2
Type	Light	Light
Accuracy Class	OIML III	OIML III
Enclosure	Die-casting Aluminum	Die-casting Aluminum
Display	30mm LED	30mm LCD w/Backlight
Capacity Available	200 / 400 / 600 / 1000 / 2000 lb	200 / 400 / 600 / 1000 / 2000 lb
Battery Life	80 Hours	80 Hours
High Quality Load Receptor		
Shackle	Stainless Steel	Stainless Steel
Hook	Rotatable	Rotatable
High Capacity Rechargeable Battery	Yes 6V/5Ah	Yes 6V/5Ah
Infrared Remote Control	Yes	Yes

Rated Capacity	Division	A	B	C	L	N.W.	G.W.
100kg / 200lb	0.05kg / 0.1 lb	20mm / 0.79"	80mm / 3.15"	24mm / 0.94"	350mm / 13.78"	4.1kg / 9.0 lb	5.2kg / 11.5 lb
200kg / 400lb	0.1kg / 0.2 lb	20mm / 0.79"	80mm / 3.15"	24mm / 0.94"	350mm / 13.78"	4.1kg / 9.0 lb	5.2kg / 11.5 lb
300kg / 600lb	0.1kg / 0.2 lb	20mm / 0.79"	80mm / 3.15"	24mm / 0.94"	350mm / 13.78"	4.1kg / 9.0 lb	5.2kg / 11.5 lb
500kg / 1Klb	0.2kg / 0.5 lb	25mm / 0.98"	85mm / 3.35"	36mm / 1.42"	370mm / 14.57"	4.3kg / 9.5 lb	5.6kg / 12.3 lb
1t / 2Klb	0.5kg / 1 lb	25mm / 0.98"	85mm / 3.35"	36mm / 1.42"	370mm / 14.57"	4.3kg / 9.5 lb	5.6kg / 12.3 lb

*Dimensions and specifications are subject to change without notice.