

# ANYLOAD<sup>®</sup>

## OCSD WIRELESS DYNAMOMETER

### USER MANUAL



**TABLE OF CONTENTS**

|   |           |
|---|-----------|
| <b>SAFE OPERATION GUIDE</b> .....                           | <b>2</b>  |
| <b>CHAPTER 1 FEATURES AND SPECIFICATIONS</b> .....          | <b>3</b>  |
| 1. Features.....  | 3         |
| 2. Main technical data.....                                 | 3         |
| 3. Specifications.....                                      | 4         |
| 4. Appearance illustration.....                             | 4         |
| 5. Power supply.....  | 5         |
| <b>CHAPTER 2 DISPLAY AND KEYS</b> .....                     | <b>5</b>  |
| 1. Dynamometer display.....                                 | 5         |
| 2. Indicator display.....                                   | 6         |
| <b>CHAPTER 3 FUNCTION GUIDE</b> .....                       | <b>7</b>  |
| 1. On/off.....  | 7         |
| 2. Zero.....  | 8         |
| 3. Tare.....  | 8         |
| 4. Peak Hold.....   | 8         |
| 5. Set time.....  | 8         |
| 6. Set date.....  | 9         |
| 7. Set CN.....  | 9         |
| 8. Set SN.....  | 9         |
| 9. Unit.....  | 9         |
| 10. Battery voltage.....                                    | 10        |
| 11. Set print method.....                                   | 10        |
| 12. Set point.....  | 11        |
| <b>CHAPTER 4 WEIGHING DATA PROCESSING</b> .....             | <b>11</b> |
| 1. Input CN&SN number.....                                  | 11        |
| 2. Statics and print.....                                   | 12        |
| 3. Print per date.....                                      | 12        |
| 4. Print per CN.....  | 12        |
| 5. Print per SN.....  | 13        |
| 6. Clear.....   | 13        |
| <b>CHAPTER 5 PARAMETER SETTINGS &amp; CALIBRATION</b> ..... | <b>13</b> |
| 1. Parameter settings.....                                  | 13        |
| 2. Calibration.....   | 16        |
| <b>CHAPTER 6 COMMUNICATION WITH PC</b> .....                | <b>17</b> |
| 1. Installing drive software.....                           | 17        |
| 2. Running weighing software.....                           | 18        |
| <b>CHAPTER 7 SIGNAL ILLUSTRATION</b> .....                  | <b>19</b> |
| <b>CHAPTER 8 TROUBLESHOOTING GUIDE</b> .....                | <b>20</b> |
| <b>CHAPTER 9 RS232 PROTOCOL</b> .....                       | <b>20</b> |

## SAFE OPERATION GUIDE :

1. Do not make lifts beyond rated load capacity of the dynamometer and the shackle(s).
2. Do not perform overhead weighing. Stay clear when Dynamometer is in operation.
3. Do not perform weighing under strong wind conditions as it may cause incorrect readings.
4. Do not perform weighing in an environment with rapid temperature changes as it may cause incorrect readings.
5. Do not attempt to open this Dynamometer; there are no serviceable parts inside.
6. Do not remove wire rope stopper from hook. For safety reasons, always apply.
7. Remove all loads from shackle or hook when not in use.
8. Before weighing, check and make sure that all hanging, load receiving elements and devices are in good condition.
9. Check hook, shackle, safety pins, and latches periodically. Contact your dealer for replacement parts in case of defect, deformities or wearing.
10. Always lift loads vertically.

## CHAPTER 1 FEATURES AND SPECIFICATIONS

### 1.1 Features

- **Body protection:** Aluminum and alloy steel capacities are powder coated.
- **Accuracy:** 0.05% for 1-50t, 0.1% for above 50t capacity.
- **Units:** Units are clearly displayed on the screen, available in the following measurement readings: Kilograms (kg), short Tons (t) pounds (lb), Newton and kilo-Newton (kN)
- **Shackles:** High tension industrial standard G2130 anchor shackle bows with galvanized finish.
- **Gravity regulation:** The acceleration of gravity can be regulated through indicator parameter settings according to different places value.
- **Functions:** Wireless indicator with many functions: ZERO, TARE, LOW BATTERY warnings, PEAK hold, overload warning. User calibration (with password).
- **Set-Point:** Two user programmable Set-Point can be used for safety and warning applications or limit weighing.
- **Body indicator keys:** 4 local mechanical keys: "ON/OFF", "ZERO", "PEAK" and "UNIT CHANGE".
- **Indicator communications:** Both RS232 serial port and USB port, solve most laptops without serial port problem. With the manufacturer's PC host computer software, not only displays weight value and stable information on the PC but can also enter the company's name, complete storage, print query and other functions.
- **Antenna:** Internal antenna
- **Function on indicator keyboard:** It can print data, time, serial number, commodity number, net weight and total weight. It can also input 9 digits head information and can store up to 2000 weighing records. It can store statistics by serial number or commodity number and statistical data. Statistical results can be printed with weighing number and total weight.

### 1.2 Main technical data

|                     |   |
|---------------------|---|
| Display             | 25mm (1") 5 digits LCD with backlight                 |
| Power on Zero Range | 20% F.S.  |
| Manual Zero Range   | 4% F.S.   |
| Tare Range          | 100% F.S.   |
| Stable Time         | ≤5 seconds  |
| Overload Indication | 100% F.S. + 9e  |
| Max. Safety Load    | 125% F.S.   |
| Ultimate Load       | 400% F.S.   |
| Dynamometer battery | "LR6 (AA)"size alkaline batteries. 1.5Vx3             |
| Indicator battery   | 7.2V/ 3.3Ah Ni-H rechargeable battery                 |
| Operating Temp.     | - 10°C ~ + 40°C                                       |
| Operating Humidity  | ≤85% RH under 20°C                                    |
| Indicator printer   | FUJITSU FTP-628 MCL101#50" high speed thermal printer |
| Wireless Distance   | Min. 80m(default) , 200m(optional)                    |
| Wireless Frequency  | 2.4GHz(default),433MHz,860MHz(optional)               |

## 1.3 Specifications

| MENU      | Capacity (kg) | Min. Weight (kg) | Division (kg) | Total counts (n) |
|-----------|---------------|------------------|---------------|------------------|
| OCSD-1t   | 1000          | 10               | 0.5           | 2000             |
| OCSD-2t   | 2000          | 20               | 1             | 2000             |
| OCSD-3t   | 3000          | 20               | 1             | 3000             |
| OCSD-5t   | 5000          | 40               | 2             | 2500             |
| OCSD-10t  | 10000         | 100              | 5             | 2000             |
| OCSD-20t  | 20000         | 200              | 10            | 2000             |
| OCSD-30t  | 30000         | 200              | 10            | 3000             |
| OCSD-50t  | 50000         | 400              | 20            | 2500             |
| OCSD-100t | 100000        | 1000             | 50            | 2000             |
| OCSD-200t | 200000        | 2000             | 100           | 2000             |

## 1.4 Appearance illustration

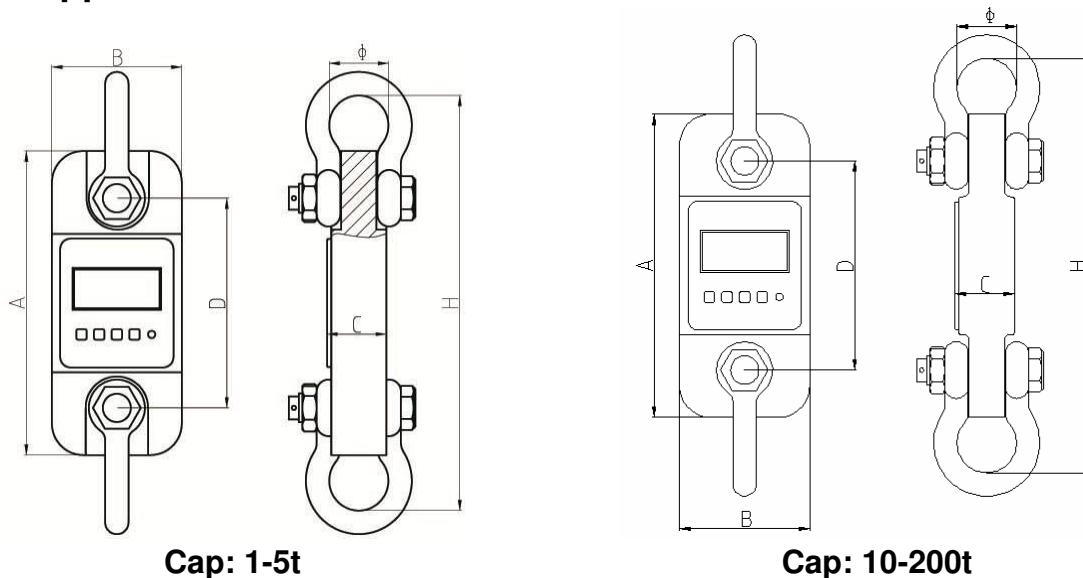

Cap: 1-5t

Cap: 10-200t

### DIMENSIONS (Dimensions shown are nominal and subject to tolerances)

| MENUL     | CAP  | A(mm) | B(mm) | C(mm) | D(mm) | φ(mm) | H(mm) | Material    |
|-----------|------|-------|-------|-------|-------|-------|-------|-------------|
| OCSD-1t   | 1t   | 245   | 112   | 37    | 190   | 43    | 335   | Aluminum    |
| OCSD-2t   | 2t   | 260   | 123   | 37    | 195   | 51    | 365   | Aluminum    |
| OCSD-3t   | 3t   | 260   | 123   | 37    | 195   | 51    | 365   | Aluminum    |
| OCSD-5t   | 5t   | 285   | 123   | 57    | 210   | 58    | 405   | Aluminum    |
| OCSD-10t  | 10t  | 320   | 120   | 57    | 230   | 92    | 535   | Alloy Steel |
| OCSD-20t  | 20t  | 375   | 128   | 74    | 260   | 127   | 660   | Alloy Steel |
| OCSD-30t  | 30   | 420   | 138   | 82    | 280   | 146   | 740   | Alloy Steel |
| OCSD-50t  | 50t  | 465   | 150   | 104   | 305   | 184   | 930   | Alloy Steel |
| OCSD-100t | 100t | 570   | 190   | 132   | 366   | 229   | 1230  | Alloy Steel |
| OCSD-200t | 200t | 720   | 265   | 183   | 440   | 280   | 1362  | Alloy Steel |

## WEIGHTS

| MODEL                     | OCSD-1t  | OCSD-2t  | OCSD-3t  | OCSD-5t   | OCSD-10t  |
|---------------------------|----------|----------|----------|-----------|-----------|
| Unit Weight (kg)          | 1.6      | 2.1      | 2.1      | 2.7       | 10.4      |
| Weight with shackles (kg) | 3.1      | 4.6      | 4.6      | 6.3       | 24.8      |
| MODEL                     | OCSD-20t | OCSD-30t | OCSD-50t | OCSD-100t | OCSD-200t |
| Unit Weight (kg)          | 17.8     | 25       | 39       | 81        | 210       |
| Weight with shackles (kg) | 48.6     | 73       | 128      | 321       | 776       |

## 1.5 Power supply

Dynamometer battery: "LR6 (AA)"size alkaline batteries. 1.5VX3

Indicator battery: 7.2V/ 3.3Ah Ni-H rechargeable battery

Current: the dynamometer average current is about DC 35mA, 3pcs new batteries can be used for about 40hours continuously.

Wireless indicator average current is about DC 50mA. Fully charged batteries can be used for about 80 hours continuously.

Low battery warning: When the digits flash, it means the battery needs to be replaced. The Dynamometer or wireless indicator will power off automatically after one hour without operation.

## CHAPTER 2 DISPLAY AND KEYS

### 2.1 Dynamometer display

#### 2.1.1 LCD Display

25mm (1") 5 digits LCD with backlight.

#### 2.1.2 Signal

a.  :

Wireless signal, when symbol appears it means signal is stable. It disappears when there is no signal and flashes when signal is weak.

b. : Battery Voltage, : Full, : Low, : Empty

c. **PEAK**: Current value is Peak Hold value (maximum value).

d. **MEM**: Appears one time when Parameter or calibration value is stored. Long time appearance means current value is Accumulation data.

e. **STB**: Stable Status.

f. **kN**: "kilo-Newton", **N**: "Newton". Tare status "N" will flash.

g. **t** : "ton"

h. **lb** : "pound"

i. **kg** : "kilogram "

#### 2.1.3. Keys

a. **ON/OFF**

1. Press "**ON/OFF**" key for 1 second, the Dynamometer will turn on.

2. In ON status, Press "**ON/OFF**" key for 1 second, the Dynamometer will turn off.

## b. ZERO

When Dynamometer is switched on with no load, but there are small digits on the screen, press this key to obtain the zero reading.

## c. UNIT

Press UNIT key, the unit on LCD will display in loop as follows: "kg" → "lb" → "N" → "kN" → "t" → "kg".

## d. PEAK

When load is changing, press this key and it will catch and display the maximum reading of the load. Press this key again, reading will return to normal.

## 2.2 Indicator display



















### 2.2.1 LCD Display

25mm (1") 5 digits LCD with backlight

### 2.2.2 Signal

Same as dynamometer signal

### 2.2.3 Key

-  : Turn on
-  : Turn off
-  : Cargo number, from 00 to 99, Set CN, to distinguish different goods
-  : Serial number, from 00000 to 99999, to distinguish different time weighing
-  : LCD Backlight
-  : Set time
-  : Set date and set digit up
-  : Repeat print current weighing data
-  : Save in memory and print current weighing data
-  : Peak function and move digit left
-  : Tare function and move digit right
-  : Set print MENU
-  : Clear memory
-  : Zero function and move digit down
-  : Statistics function
-  : Return to previous menu
-  : Select menu
-  : Confirm

## CHAPTER 3 DYNAMOMETER FUNCTION GUIDE

( ) means the key on the dynamometer

[ ] means the display content

### 3.1 ON/OFF

#### ◆TURN ON dynamometer



| OPERATION | DISPLAY    | ILLUSTRATION                             |
|-----------|------------|--|
| (ON/OFF)  | [ 88888 ]  | Displays twice, self test                |
|           | [ Ert ]    | Displays twice                           |
|           | [ U=3.72 ] | Displays current software version        |
|           | [ CH=E3 ]  | Displays current wireless channel E3     |
|           | [ 5000 ]   | Displays capacity, e.g. 5t               |
|           | [ U=3.98 ] | Displays current battery voltage is 3.98 |
|           | [ ——— ]    | Waiting stable                           |
|           | [ 0 ]      | Displays current load, generally is 0    |

#### ◆TURN ON indicator

| OPERATION   | DISPLAY            | ILLUSTRATION  |
|---|--------------------|---|
| Press  | [ 88888 ]          | Displays twice, self test   |
|   | [ Ert ]            | Displays twice  |
|   | [ u 1.08 ]         | Displays current indicator software version   |
|   | [ CH=E3 ]          | Displays current wireless channel E3  |
|   | [ U=7.xx ]         | Displays current indicator battery voltage is 7.xx  |
|   | [ 0 ] or [ noSlg ] | If display reads 0, it means the indicator can communicate with the dynamometer, if display reads “noSlg”, it means there is no signal from |

**Note** :Indicator battery voltage is normally between [ U 6.80 ]to [ U 8.20 ], if it is below [ U 6.80 ], the display will flash. Battery should be recharged.

#### ◆TURN OFF dynamometer

|   |                  |  |
|---|------------------|--|
| 1 | Manual Power OFF | Press (ON/OFF) key for 1 Second  |
| 2 | Remote Power OFF | Press  key to select “OFF”, press  Key |
| 3 | Auto Power OFF   | Choose turn off method in parameter setting, the dynamometer will display [ - ] after no operation at 15minutes to save power  |

## ◆TURN OFF indicator

|   |                  |   |
|---|------------------|---|
| 1 | Manual Power OFF | Press <b>OFF</b> key for 1 Second   |
| 2 | Auto Power OFF   | The indicator will turn off automatically after 3 minutes if not in operation |



## 3.2 ZERO

|   | OPERATION   | DISPLAY | When Dynamometer is turned on, generally it displays [ 0 ], if display reads small digits when there is no load, press this key. |
|---|---|---------|--|
| 1 | Press (ZERO)  | [ 0 ]   |  |
| 2 | Press  |         |  |











## 3.3 TARE

|  | OPERATION   | DISPLAY | After turning on, hanging tare weight such as sling, cable at first, press this key, "TARE" light on, then the scale will display net weight of the goods. |
|--|---|---------|--|
|  | Press  | [ 0 ]   |  |











## 3.4 PEAK HOLD

| OPERATION   | ILLUSTRATION                                     |
|---|--|
| Press (PEAK) or  | Catch and display maximum value of changing load |
| Press (PEAK) or  | Reading return to normal                         |

## 3.5 SET TIME

| OPERATION   | DISPLAY   | ILLUSTRATION  |
|---|-----------|---|
| Press  | [ hh ]    | Displays current clock  |
| Press  | [ mm-ss ] | Displays current minute and second  |
| Press  | [ mm-ss ] | Press  until digit m flashes,<br>Press  ,  ,  ,  to set current time,<br>Press  to set current clock |
| Press  | [ 0 ]     | Save set time and return  |

## 3.6 SET DATE

| OPERATION   | DISPLAY   | ILLUSTRATION   |
|---|-----------|--|
| Press  | [ YYYY ]  | Displays current year  |
| Press  | [ mm-dd ] | Displays current month and date  |
| Press  | [ mm-dd ] | Press  until digit m flashes,<br>Press  ,  ,  ,  to set current date,<br>Press  to set current year |
| Press  | [ 0 ]     | Save set date and return   |

### 3.7 SET CN(CARGO NUMBER)

| OPERATION               | DISPLAY | ILLUSTRATION  |
|-------------------------|---------|---|
| Press <b>CN</b>         | [ 00 ]  | Displays current cargo number, press <b>DATE</b> , <b>ZERO</b> , <b>TARE</b> , <b>PEAK</b> to set new cargo number, |
| Press <b>SAVE PRINT</b> | [ 0 ]   | Save and return   |

**Attn: After set new CN, it means that the goods weigh later are classified to this CN**

### 3.8 SET SN(SERIAL NUMBER)

| OPERATION               | DISPLAY | ILLUSTRATION  |
|-------------------------|---------|---|
| Press <b>SN</b>         | [ 00 ]  | Displays current serial number, press <b>DATE</b> , <b>ZERO</b> , <b>TARE</b> , <b>PEAK</b> to set new serial number, |
| Press <b>SAVE PRINT</b> | [ 0 ]   | Save and return   |

**Attn: After setting new SN, it means that the goods weigh later are classified to this SN. CN, SN mainly used for distinguish different goods.**

### 3.9 UNIT













|   | OPERATION                 | DISPLAY   | ILLUSTRATION  |
|---|---------------------------|-----------|---|
| 1 | Press <b>MENU</b> 4 times | [ Unit ]  |   |
|   | Press <b>ENTER</b>        | [ Un=0 ]  | Un=0, the unit is kg, press <b>DATE</b> to select unit from 0-4, 1 means lb, 2 means N, 3 means KN, 4means ton. |
|   | Press <b>MENU</b>         | [ 0 ]     | Confirm unit chosen and return  |
| 2 | Press (UNIT)              | [ Un =0 ] | The dynamometer will display kg, lb, N,   |

### 3.10 BATTERY VOLTAGE

| OPERATION                  | DISPLAY   | ILLUSTRATION                                |
|----------------------------|-----------|---|
| Press <b>MENU</b> 3 times, | [ dC ]    |   |
| press <b>ENTER</b>         | [ U *.* ] | Display current dynamometer battery voltage |
| Press <b>ESC</b>           | [ 0 ]     | Return                                      |

**Note :** Dynamometer battery voltage is normally between [ U 3.50 ] to [ U 4.70 ] , if below [ U 3.10 ] , the display will flash. Battery should be replaced.

## 3.11 SET PRINT METHOD















| OPERATION   | DISPLAY   | ILLUSTRATION  |
|---|---|---|
| Press    | [[ AutoP ]] or<br>[[ HAndP ]]                   | Displays current print method, AutoP means auto print, once weighing over 20e and stable, indicator will auto print the weighing date. HAndP means manual print, you have to press  key to print data when weighing is stable, press  to shift from these two items |
| Press    | [[ nSPrt ]] or<br>[[ nHPrt ]] or<br>[[ noPrt ]] | nSPrt means simple print, only print no, weighing date, nHPrt means with head print, print date, time, CN,SN. noPrt means do not print, press  to shift from these three items   |
| Press    | [[ CHn ]] or<br>[[ Eng ]]                       | CHn means print in Chinese, Eng means print in English, press  to shift from these two items  |
| Press  | [[ Hd.OFF ]]<br>or [[ Hd.On ]]                  | Hd.OFF means print without head, Hd.On means print with head, press  to shift from these two items   |
| Press  | [[ 1.XXXX ]]                                    | Input head, XXXX is character code, 1 means first character, press  for second, third character, total of nine characters, for character code list please  |
| Press  | [[ 0 ]]   | Save all your settings and return   |

Attn: The default **setting** is HandP, nHPrt, Eng, Hd.OFF

## 3.12 SET POINT

There are two user programmable Set-Points SP1 and SP2 that can be used for safety and warning applications or for limit weighing.

—                1 LO  SP1 1 HI          2 LO SP2 2 HI          

| OPERATION   | DISPLAY                        | ILLUSTRATION  |
|---|--------------------------------|---|
| Press  twice   | [[ SETUP ]]                    | Confirm, enter into parameter setting program   |
| Press  until display   | [[ SP1 ]]                      | Set point 1   |
| Press  to confirm  | [[ 1 OFF ]]                    | The screen will display 1 OFF, if parameter is set, it will display set value.  |
| Press  to choose   | [[ 1 HI ]] or<br>[[ 1 LO ]]    | There are 3 choices, 1 OFF means you do not set point, 1 HI means the indicator will alarm when load exceeds the value you set, 1 LO means the indicator will alarm when load is smaller than the value |
| Press  to confirm  | [[ 02000 ]]                    | The screen will display 02000, if parameter is set, the screen will display set value.  |
| Press  and  | [[ 01000 ]]                    | Set “1 HI” or “1 LO” Value. e.g. 1000kg   |
| Press    | [[ SP2 ]]                      | Set point 2   |
| Press  to confirm  | [[ 2 OFF ]]                    | The screen will display 2 OFF, if parameter is set, it will display set value.  |
| Press  to choose   | [[ 2 HI ]]<br>or<br>[[ 2 LO ]] | There are 3 choices, 2 OFF means you do not set point, 2 HI means the indicator will alarm when load exceeds the value you set, 2 LO means the indicator will alarm when load is smaller than the value |
| Press  to confirm  | [[ 01200 ]]                    | The screen will display 01200, if parameter is set, the screen will display set value.  |
| Press  and  | [[ 03000 ]]                    | Set “2 LO” or “2 HI” Value. e.g. 3000kg, input 3000   |
| Press    | [[ 0 ]]                        | Return to weighing status, set point finish   |









## Chapter 4 WEIGHING DATA PROCESSING

In normal weighing status, every time weighing data will be saved in memory, and number it as No:0001, No:0002 etc, 580 indicator can save up to 2000 weighing data









### 4.1 Input in CN & SN number

CN and SN are mainly used to classify different goods. Before weighing, you can input it as Chapter 3-7, 3-8, CN, SN can be used at the same time. After setting, the weighing data will be classified to these CN, SN. The default is CN:00, SN:00000

### 4.2 Statics and print

| OPERATION   | DISPLAY                 | ILLUSTRATION  |
|---|-------------------------|---|
| Press    | [[ COU <sup>n</sup> t]] | Press  to print total data record, but after it is turned off, it cannot print again.   |
| Press  | [[ P0001]]              | Press  to print No:0001 data, you can press  to choose different no and print. |
| Press  | [[ LFP <sup>r</sup> t]] | Press  to forward paper without print   |
| Press  | [[ 0]]                  | Return to weighing status   |

### 4.3 Print per date

| OPERATION   | DISPLAY    | ILLUSTRATION   |
|---|------------|--|
| Press  | [[ YYYY]]  | Displays current year  |
| Press  | [[ mm-dd]] | Displays current date  |
| Press  | [[ mm-dd]] | Press  until digit m flashes, press  ,  ,  ,  to set date which you want to print data. |
| Press  | [[ 0]]     | The indicator will print all time weighing data which operated in the date you chose, total weight and total times. Then return to weighing status   |



## 4.4 Print per CN

| OPERATION          | DISPLAY  | ILLUSTRATION   |
|--------------------|----------|--|
| Press <b>CN</b>    | [[ XX ]] | It means current CN is XX, press  to set CN in which you want to print data. |
| Press <b>COUNT</b> | [[ 0 ]]  | The indicator will print all time weighing data classified in the CN set, total weight and total times. Return to weighing status.                             |

## 4.5 Print per SN





| OPERATION          | DISPLAY     | ILLUSTRATION  |
|--------------------|-------------|---|
| Press <b>SN</b>    | [[ XXXXX ]] | It means current CN is XXXXX, press  to set date in which you want to print data. |
| Press <b>COUNT</b> | [[ 0 ]]     | The indicator will print all time weighing data classified in SN set, total weight and total times. Indicator will return to weighing status.                       |







## 4.6 Clear





| OPERATION          | DISPLAY     | ILLUSTRATION   |
|--------------------|-------------|--|
| Press <b>CLEAR</b> | [[ CLrP1 ]] | Press  will clear current weighing data and return to weighing status     |
| Press <b>MENU</b>  | [[ CLrP2 ]] | Press  will clear total weighing data saved and return to weighing status |
| Press <b>COUNT</b> | [[ 0 ]]     | The indicator will print all time weighing data which operated in the date you chose, total weight, and total times. Then return to weighing status.         |









## CHAPTER 5 PARAMETER SETTING & CALIBRATION







### 5.1 Parameter setting





| OPERATION  | DISPLAY | ILLUSTRATION   |
|--|---------|--|
| Press  key twice  | 〔SETUP〕 | Confirm, enter into parameter setting program  |
| Press             | 〔FS=06〕 | The screen will display FS=06 · if dynamometer is calibrated, it will display capacity.  |
| Press  to choose  | 〔FS=05〕 | Choose capacity, the screen will display 02/03/05/06/10/15/20/30/50/60/75/80 circularly. Choose cap: 5000kg/2kg as an example, choose FS=05, See following list about FS, Id, Pt chosen. |
| Press  to confirm | 〔Id=02〕 | The screen will display Id=02, if dynamometer is calibrated, it will display calibrated division.  |

|  |         |   |
|--|---------|---|
| Press  to choose  | 〔Id=02〕 | Choose division, it will display 01/02/05/10/20 circularly. 5000kg dynamometer division is 2kg, so choose Id=02   |
| Press             | 〔Pt=0〕  | The screen will display Pt=0, if dynamometer is calibrated, it will display calibrated decimal position   |
| Press  to choose  | 〔Pt=0〕  | Choose decimal position, the screen will display 0/1/2/3 circularly, 0=xxxxx, 1=xxxx.x, 2=xxx.xx, 3=xx.xxx · Cap.5000kg , choose Pt=0   |
| Press  to confirm | 〔Ab=24〕 | Displays zero range , A: zero range by hand; B: zero range automatically, 0~5 total 6 options: 0=0%F.S; 1=2%F.S; 2=4%F.S; 3=10%F.S; 4=20%F.S; 5=50%F.S. Generally do not change this parameter. |
| Press  to confirm | 〔Cd=11〕 | The screen will display Cd=11, if Dynamometer is calibrated, it will display calibrated value.  |
| Press  to choose  | 〔Cd=12〕 | C: zero-tracking range, 0~5 total of 6 options; 0=0d; 1=0.5d; 2=1d; 3=1.5d; 4=2d; 5=2.5d<br>d: display speed, 0~2 total 3 options; 0=slow; 1=average; 2=fast; before calibration, set Cd=00 to  |

|  |          |   |
|--|----------|---|
|  |          | achieve high accuracy, after calibration, set Cd=11 again, generally choose Cd=12 when ex-stock.  |
| Press  to confirm | [[LL=2]] | The screen will display LL=2, if dynamometer is calibrated, it will display calibrated value.   |
| Press  to choose  | [[LL=1]] | LL: filter parameter, 0~5 total 6 options, from smallest to biggest, before calibration, set LL=0, after calibration, set LL=1, generally choose LL=1 when ex-stock.. |
| Press  to confirm | [[Un=0]] | The screen will display Un=0, if dynamometer is calibrated, the screen will display calibrated unit.  |
| Press  to choose  | [[Un=0]] | Choose unit, Un=0:kg, Un=1: lb, Un=2: N,Un=3: KN, Un=4: ton, Generally, choose Un=0 when ex-stock.  |

|   |                         |   |
|---|-------------------------|---|
| Press  to confirm  | [[OFF 1]]               | The screen will display OFF 1, if dynamometer is calibrated, it will display calibrated value.  |
| Press  to choose   | [[OFF 2]]               | Choose turn off method, 0~2 total 3 options; 0: turn off by hand; 1: if no operation, the screen will display ----- after 15minutes to save power; 2: |
| Press  to confirm  | [[SP1 ]]                | Set point 1   |
| Press  to confirm  | [[1 OFF]]               | The screen will display 1 OFF, if parameter set, it will display set value.   |
| Press  to choose   | [[1 HI]] or<br>[[1 LO]] | There are 3 choices,1 OFF means you do not set point, 1 HI means the indicator will alarm when load exceeds the value you set, 1 LO means the         |
| Press  to confirm  | [[02000]]               | The screen will display 02000, if parameter is set, the screen will display set value.  |
| Press  and  to change value | [[01000]]               | Set "1 HI" or "1 LO" Value. e.g. 1000kg   |
| Press  to confirm  | [[ SP2]]                | Set point 2   |

|   |                                |   |
|---|--------------------------------|---|
| Press  to confirm  | [[ 2 OFF ]]                    | The screen will display 2 OFF, if parameter is set, it will display set value.  |
| Press  to choose   | [[ 2 HI ]]<br>or<br>[[ 2 LO ]] | There are 3 choices, 2 OFF means you do not set point, 2 HI means the indicator will alarm when load exceeds the value you set, 2 LO means the indicator will alarm when load is smaller than the |
| Press  to confirm  | [[ 01200 ]]                    | The screen will display 01200, if parameter is set, the screen will display set value.  |
| Press  and  to change value | [[ 03000 ]]                    | Set "2 LO" or "2 HI" Value. e.g.3000kg,input 3000   |
| Press    | [[ g= ]]                       | Acceleration of gravity   |

|  |                      |   |
|--|----------------------|---|
| Press  and  and  to change value | [[ 9.7930 ]]         | The screen will display 9.7930, if dynamometer is calibrated, it will display calibrated value. User can change it according to local area g value, the value range is 9.783-9.832. |
| Press   | [[ End ]]<br>[[ 0 ]] | Confirm above parameter setting. Exit parameter setting program.  |









**The capacity you choose relates to divisions and decimal position, below is a detailed list:**

| CAPACITY/DIVISION | FS (CAP) | Id (DIVISION) | Pt (Decimal position) |
|-------------------|----------|---------------|-----------------------|
| 1000kg/0.5kg      | 10       | 05            | 1                     |
| 2000kg/1kg        | 02       | 01            | 0                     |
| 3000kg/1kg        | 03       | 01            | 0                     |
| 5000kg/2kg        | 05       | 02            | 0                     |
| 10000kg/5kg       | 10       | 05            | 0                     |
| 15000kg/5kg       | 15       | 05            | 0                     |
| 20000kg/10kg      | 20       | 10            | 0                     |
| 30000kg/10kg      | 30       | 10            | 0                     |
| 50000kg/20kg      | 50       | 20            | 0                     |

100t, 200t use special software, no need to set FS, Id, Pt.

## 5.2 Calibration

User must set all parameters before calibration

| OPERATION   | DISPLAY     | ILLUSTRATION   |
|---|-------------|--|
| Turn on dynamometer and indicator   | [[ 0 ]]     | Take Cap:5000kg dynamometer as an example, make sure it displays [[ 0 ]] before calibration, you can hang tare weight first, then turn on to get zero reading  |
| Press  8 times,  | [[ CLibr ]] | Access calibration mode  |
| Press    | [[ CAL 1 ]] | Enter into one point calibration program   |
| Press    | [[ CALSP ]] | Zero point calibration   |
| Press    | [[ LoAd ]]  |  |
| Hanging standard weight, e.g. 3000kg  |             | Waiting until STB signal on screen   |
| Press   | [[ 5000 ]]  | Display capacity you chose in parameter setting. Wait until "STB" signal display is on screen.   |
| Press  and  to change value | [[ 03000 ]] | Press  to change value, press  to move the digit, input actual weight 3000kg |
|   | [[ ----- ]] | Confirm and store  |
|   | [[ -oL- ]]  |  |
|   | [[ End ]]   | Calibration finished   |
|   | [[ 3000 ]]  |  |

**Attention: the standard load should be more than 20% capacity, it is better to use full capacity standard load**

## CHAPTER 6 COMMUNICATION WITH PC

580 wireless indicator has a USB port which can input weighing data into PC

### 6.1 Installing drive software

When 580 USB kit is connected to the PC for first time, PC will request drive software, please run drive software. The drive software is attached to CD ROM. Insert CD ROM, running "VCP\_1.3.1\_Setup".

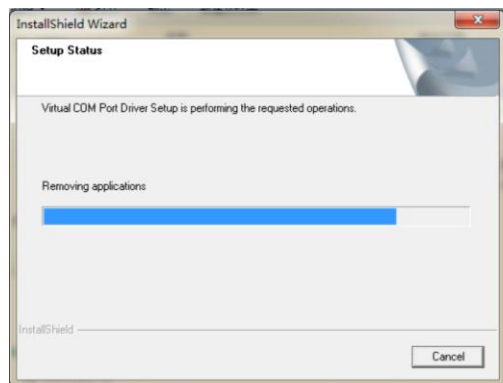
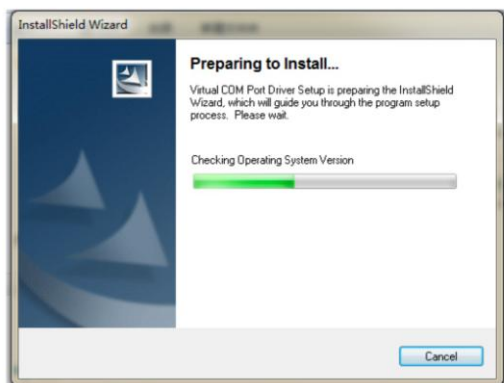

After "VCP\_1.3.1\_Setup" is running, plug in USB kit to PC. The PC will automatically find it. Open device manager to check if virtual com port communication was successful or not. If the device manager has below pictorial prompts it means it was successful.



**Note:** The port number is random, if the port number is more than 4, you need to change it, normally it can be changed to "COM3".

## 6.2 Run weighing software

After installing drive software, you can run PC software  in CD ROM, and the PC displays as follows:

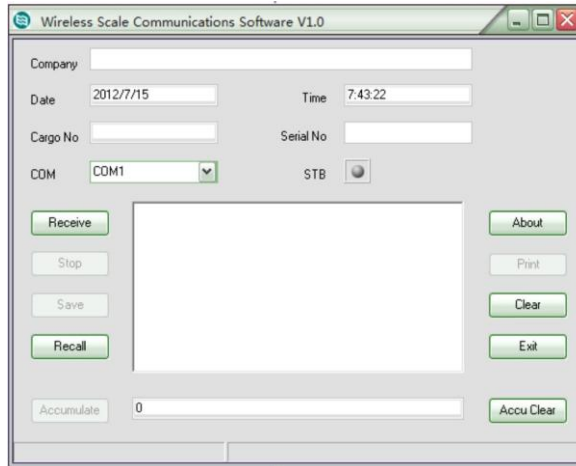

Select COM port number same as device manager showed, generally choose COM3, the PC displays as follows:

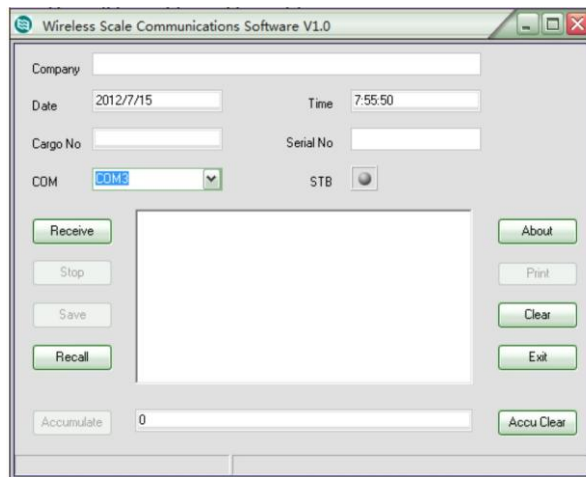

Then Click “Receive” button



Occasionally, the PC will mention to check port COM3, if you are sure you selected port COM3,

just ignore it and click “Receive” button again.

When “STB” is changed to red color, it means dynamometer load is stable, meanwhile, you can click “SAVE” button to save weighing value as “\*.ini” file, you can select file path and file name to save. When you want to check those files which you saved, just click “RECALL” button.

## CHAPTER 7 DISPLAY ILLUSTRATION

| DISPLAY    | ILLUSTRATION  | REMARK  |
|------------|---|---|
| 〔noSlg〕    | Without wireless signal                             | Distance is too far.                                |
| 〔SEtUP〕    | Enter into parameter setting                        |   |
| 〔UAdJ 〕    | Enter voltage calibration                           |   |
| 〔LoAd〕     | Calibration point                                   |   |
| 〔- - - - 〕 | Exceed high limit                                   | Tare weight cannot exceed full capacity             |
| 〔..... 〕   | Exceed low limit                                    | Tare weight cannot be negative                      |
| 〔-----〕    | Waiting stable                                      |   |
| 〔Err10〕    | Weight less than Min. Capacity                      | Cannot accumulate the value                         |
| 〔Err11〕    | Accumulated times overflow                          | Cannot accumulate after 30times                     |
| 〔Err12〕    | Accumulated weight overflow                         | Cannot accumulate after 99999                       |
| 〔Err13〕    | Error in repeat accumulation                        | Cannot accumulate one weight repeatedly             |
| 〔no***〕    | Current accumulation times                          |   |
| 〔H****〕    | Front four digits of accumulated                    | Total weight= front four digits + rare four digits  |
| 〔L****〕    | Rare four digits of accumulated                     | Total weight = front four digits + rare four digits |
| 〔 CLr 〕    | Ask if you really want to delete accumulated weight | In case error deletion                              |
| 〔noCLr〕    | Give up deletion                                    |   |
| 〔88888〕    | Confirm deletion                                    |   |
| 〔 - - - 〕  | Input value is too large                            | When you input tare or weight value                 |
| 〔 --- 〕    | Input value is too small                            | When you input tare or weight value                 |
| 〔noACC〕    | No any accumulated content                          | When you check accumulation                         |
| 〔-oL0- 〕   | Overload warning                                    | Tare + Net weight exceed full capacity + 9e         |
| 〔-oL1- 〕   | Overload warning                                    | Tare + Net weight exceed full capacity 125%         |
| 〔-Lb- 〕    | Low battery warning                                 | Turns off automatically one minute later            |
| 〔U*,.**〕   | The voltage of current battery                      |   |
| 〔 End 〕    | End   | When parameter setting or calibration are           |
| 〔 OFF 〕    | Turn off  |   |
| 〔Unstb〕    | Input value before STB light on                     |   |

## CHAPTER 8 TROUBLESHOOTING GUIDE

| PROBLEM  | POSSIBLE CAUSE                                  | SOLUTION                                 |
|--|---|--|
| No display   | Defective battery                               | Replace                                  |
|  | Defective button                                | Requires authorized service              |
|  | Power button not properly pressed               | Press ON/OFF key firmly in three seconds |
| Digits flash   | Low battery                                     | Replace battery                          |
| Display does not respond to load changes                   | Faulty load cell or PCB                         | Requires authorized service              |
|  | Out of calibration                              | Re- calibration                          |
| Display experiences excessive Zero drift between weighment | Dynamometer does not stabilize after turning on | After turning on, heating 3-5 minutes    |
| Displayed weight shows large error                         | Dynamometer not Zeroed before applying weight   | Depress ZERO before applying weight      |
|  | Requires recalibration                          | See calibration                          |
|  | Kg/lb wrong selection                           | See operation                            |
| Wireless distance shortened                                | Wireless indicator's battery is low             | Replace battery.                         |

## CHAPTER 9 RS232 PROTOCOL

| Pre-code |    | Data(ASCII) |      |      |      |             | 0X<br>+/- (0 means +<br>F means -)<br>X is decimal<br>position | 39 39<br>Commodity<br>number | F0<br>Stable<br>Signal<br>F0:<br>(stable)<br>00:<br>(unstable) | F0<br>Wireless<br>Signal<br>F0:<br>Have<br>signal<br>00:<br>Without<br>signal |
|----------|----|-------------|------|------|------|-------------|--|------------------------------|--|---|
| FF       | AA | data<br>(H) | data | data | data | data<br>(L) |  |                              |  |   |
|          |    |             |      |      |      |             |  |                              |  |   |

### RS-232 Setup Instructions Communication Configuration

Port: COM1  
 Baud Rate: 4800  
 Data Bits: 8  
 Stop Bits: 1  
 Parity: None  
 Display mode: HEX