

108TAAL

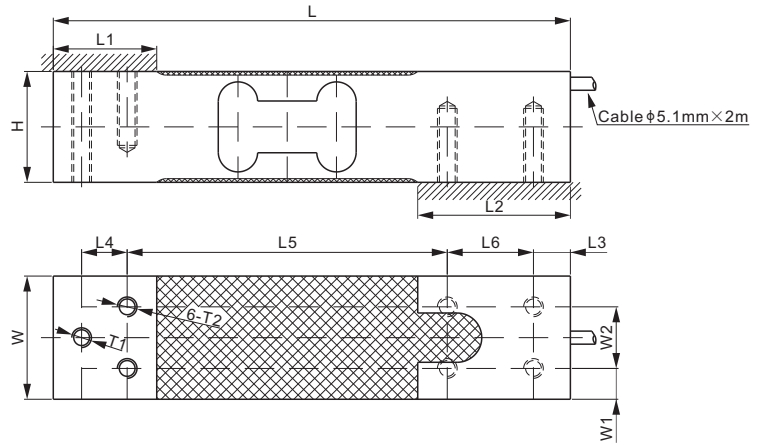

Aluminum

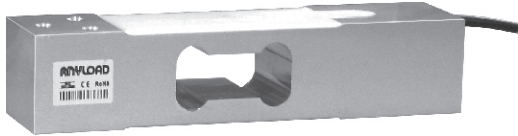

DIMENSIONS

RATED CAPACITY	H	L	L1	L2	L3	L4	L5	L6	W	W1	W2	T1	T2
kg/mm													
30-150	45.0	210.0	42.0	62.0	15.0	18.5	130.0	35.0	50.0	12.5	25.0	M8	M8 Depth30
lb/inches (conversion of above dimensions)													
66-330	1.77	8.27	1.65	2.44	0.59	0.73	5.12	1.38	1.97	0.49	0.98	M8	M8 Depth1.2

SPECIFICATIONS

Type	YZ108	Recommended Excitation	10V (15V Maximum)
Full Scale Output	1.0 ± 10% mV/V	Reference Max. Platform Size	400 × 400 mm
Zero Balance	± 0.02 mV/V	Insulation Resistance	>2 [50V DC] GΩ
Non-linearity	< ± 0.017%	Nominal Temperature Range	-10°C to 40°C / 14°F to 104°F
Repeatability	< ± 0.017%	Safe Overload	150% of full scale
Hysteresis Error	< ± 0.017%	Breaking Overload	300% of full scale
Creep in 30 min.	< ± 0.023%	Seal Type / IP Rating	Environmentally Sealed / IP66
Input Resistance	415Ω ± 15	Cable Color Code	Exc+ Red Exc- Black
Output Resistance	350Ω ± 3		Sig+ Green Sig- White
Element Material	Aluminum		Shield Bare

PART NUMBER

Rated Capacity	Part No.	Shipping Weight (kg) Approx.
30kg.....	108TAAL-30kg.....	1.2
60kg.....	108TAAL-60kg.....	1.2
100kg.....	108TAAL-100kg.....	1.2
150kg.....	108TAAL-150kg.....	1.2

INTERCHANGEABLE PRODUCTS

Manufacturer	Model
A&D.....	LC-4103

30kg-150kg: OIML C3