

# 102THM5

## Alloy Steel

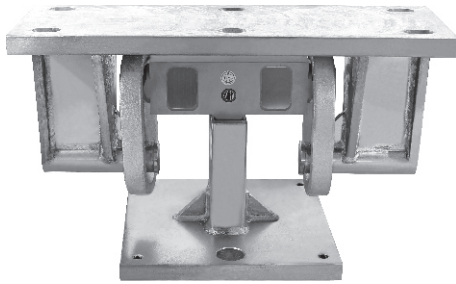

### Features:

- Assembles: 102TH double ended beam load cell
- Capacities: 50-75Klb
- Center pivoted, end-loaded and completely self-centering
- Multi-directional movements in the horizontal plane
- Links provide optimal loading conditions for the load cell
- No check rods required

Load Cell Certifications:



Load Cell Not Included.

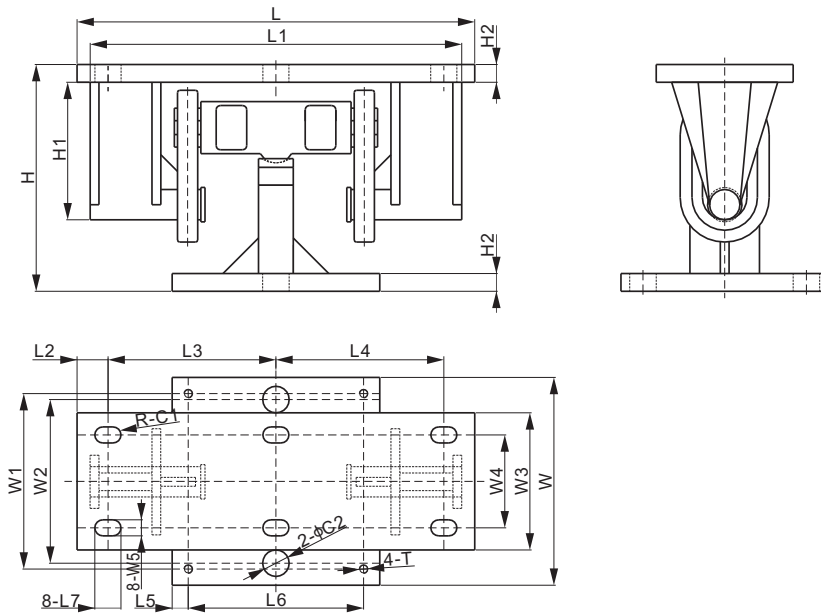

### DIMENSIONS

LOAD CELL CAPACITY	C1	C2	H	H1	H2	L	L1	L2	L3	L4	L5	L6	L7	W	W1	W2	W3	W4	W5	T
<b>Klb/inches</b>																				
50-75	R0.45	1.5	12.82	7.78	1.00	22.5	21.02	1.75	9.50	9.50	0.91	9.92	1.48	11.75	9.92	9.25	7.75	5.25	0.91	1/2-20UNF
<b>kg/mm</b> (conversion of above dimensions)																				
22,679.6-34,019.4	R11.55	38.1	325.6	197.6	25.4	571.5	534	44.5	241.3	241.3	23.2	252	37.5	298.4	252	235	196.9	133.4	23.1	1/2-20UNF

### PART NUMBER

Load Cell Capacity	Part No.	Shipping Weight (kg) Approx.
50Klb-75Klb	102THM5-(50-75)Klb	69.5

### INTERCHANGEABLE PRODUCTS

Manufacturer	Model
Rice Lake	Translink

WEIGH MODULES