

# 102BS

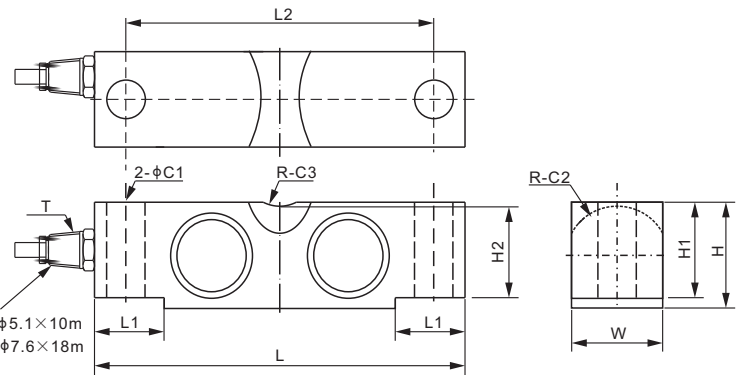

## Stainless Steel

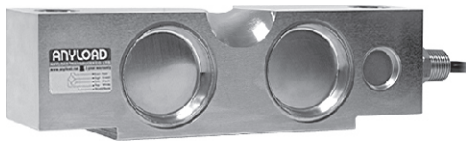

Capacity ≤ 25Klb Cable φ5.1×10m  
Capacity ≥ 40Klb Cable φ7.6×18m

### DIMENSIONS

RATED CAPACITY	C1	C2	C3	H	H1	H2	L	L1	L2	W	T
<b>Klb/inches</b>											
10-25	0.68	0.90	0.75	1.94	1.70	1.63	7.75	1.38	6.50	1.69	1/4-18 NPT
40-75	1.06	1.37	1.00	2.94	2.65	2.55	10.25	1.93	8.50	2.44	1/2-14 NPT
100	1.06	1.37	1.00	3.44	2.65	2.55	10.25	1.93	8.50	2.44	1/2-14 NPT
<b>kg/mm</b> (conversion of above dimensions)											
4,535.9-11,339.8	17.3	22.9	19.1	49.3	43.2	41.3	196.9	35.1	165.1	42.9	1/4-18 NPT
18,143.7-34,019.4	27.0	34.8	25.4	74.7	67.3	64.8	260.4	48.9	215.9	62.0	1/2-14 NPT
45,359.2	27.0	34.8	25.4	87.4	67.3	64.8	260.4	48.9	215.9	62.0	1/2-14 NPT

### SPECIFICATIONS

<b>Full Scale Output</b>	3.0 ± 0.25% mV/V	<b>Recommended Excitation</b>	10V (15V Maximum)
<b>Zero Balance</b>	± 0.02 mV/V	<b>Insulation Resistance</b>	>2 [ 50V DC ] GΩ
<b>Non-linearity</b>	< ± 0.030%	<b>Compensated Temperature Range</b>	-10°C to 50°C / 14°F to 122°F
<b>Repeatability</b>	< ± 0.017%	<b>Safe Overload</b>	150% of full scale
<b>Hysteresis Error</b>	< ± 0.023%	<b>Breaking Overload</b>	300% of full scale
<b>Creep in 30 min.</b>	< ± 0.023%	<b>Seal Type / IP Rating</b>	Welded Seal / IP68
<b>Input Resistance</b>	700Ω ± 10	<b>Cable Color Code</b>	Exc+ Red      Exc- Black
<b>Output Resistance</b>	700Ω ± 5		Sig+ Green    Sig- White
<b>Element Material</b>	2Cr13 Stainless Steel		Shield Bare

### PART NUMBER

Rated Capacity	Part No.	Shipping Weight (kg) Approx.
10Klb	102BS-10Klb-YZ	2.9
20Klb	102BS-20Klb-YZ	2.9
25Klb	102BS-25Klb-YZ	2.9
40Klb	102BS-40Klb-YZ	8.0
50Klb	102BS-50Klb-YZ	8.0
60Klb	102BS-60Klb-YZ	8.0
75Klb	102BS-75Klb-YZ	8.0
100Klb	102BS-100Klb-YZ	11.0

### INTERCHANGEABLE PRODUCTS

Manufacturer	Model
Coti Global	CG-58-SSW
Rice Lake	RL75060S
Vishay Revere Transducers	9303
Vishay Sensortronics	.65058S