

### Features:

- Assembles: 101NH S-beam load cell
- Capacities: 50lb-20Klb
- Allows for high accuracy tension loading

Load Cell Certifications:



Load Cell Not Included.

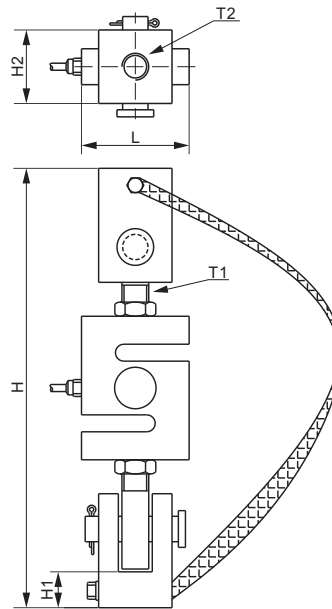

### DIMENSIONS

LOAD CELL CAPACITY	H	H1	H2	L	T1	T2
<b>lb/inches</b>						
50-250	7.00	0.75	1.55	2.00	1/4-28 UNF-2B	1/2-13 UNC-2B
500-3,000	9.50	1.00	2.80	2.00	1/2-20 UNF-2B	3/4-10 UNC-2B
5,000-10,000	12.25	1.00	2.80	3.00	3/4-16 UNF-2B	3/4-10 UNC-2B
15,000	18.00	1.75	3.60	3.50	1-14 UNS-2B	1-1/2-6 UNC-2B
20,000	20.00	1.75	3.60	4.50	1-1/4-12 UNF-2B	1-1/2-6 UNC-2B
<b>kg/mm</b> (conversion of above dimensions)						
22.7-136.1	177.8	19.1	39.4	50.8	1/4-28 UNF-2B	1/2-13 UNC-2B
226.8-1,360.8	241.3	25.4	71.1	50.8	1/2-20 UNF-2B	3/4-10 UNC-2B
2,268-4,535.9	317.5	25.4	71.1	76.2	3/4-16 UNF-2B	3/4-10 UNC-2B
6,803.9	457.2	44.5	91.4	88.9	1-14 UNS-2B	1-1/2-6 UNC-2B
9,071.8	508.0	44.5	91.4	114.3	1-1/4-12 UNF-2B	1-1/2-6 UNC-2B

### PART NUMBER

Load Cell Capacity	Part No.	Shipping Weight (kg) Approx.
50lb-250lb.....	101NHM2-(50-250)lb .....	2.6
500lb-3Klb .....	101NHM2-(0.5-3)Klb.....	2.8
5Klb-10Klb .....	101NHM2-(5-10)Klb.....	3.2
15Klb.....	101NHM2-15Klb .....	13.0
20Klb.....	101NHM2-20Klb .....	13.3