

# 563WS; 563WS30



## Stainless Steel



563WS; 563WS30-37.5Klb:

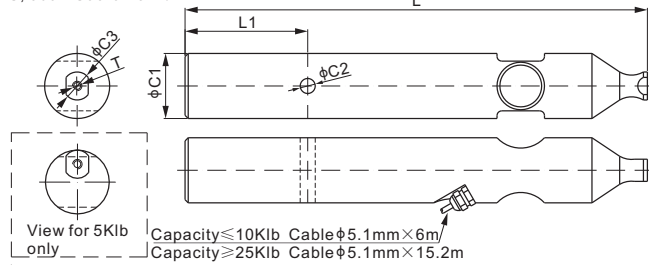

563WS30-50Klb:

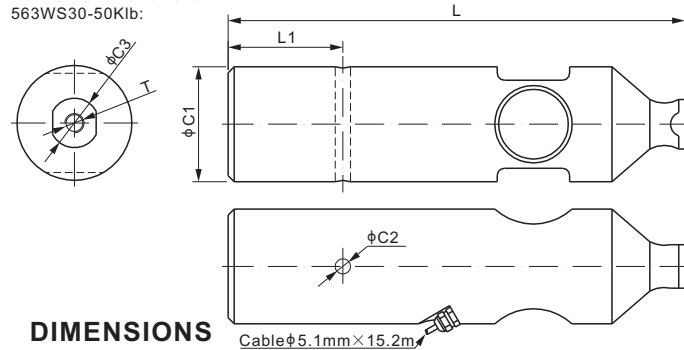

### DIMENSIONS

RATED CAPACITY	C1	C2	C3	L	L1	T
<b>563WS:</b>						
<b>lb/inches</b>						
1,250	1.25	0.31	0.63	11.50	3.00	#8-32
2,500	1.62	0.37	0.70	11.50	3.00	#6-32
5,000	2.00	0.37	0.88	10.88	3.05	#8-32
10,000	2.50	0.37	0.88	12.63	3.05	#8-32
25,000	3.50	0.50	1.75	14.88	3.05	5/16-18
<b>kg/mm</b> (conversion of above dimensions)						
567	31.8	7.9	16.0	292.1	76.2	#8-32
1,134	41.1	9.5	17.8	292.1	76.2	#6-32
2,268	50.8	9.5	22.4	276.4	77.5	#8-32
4,535.9	63.5	9.5	22.4	320.8	77.5	#8-32
11,339.8	88.9	12.7	44.5	378.0	77.5	5/16-18
<b>563WS30:</b>						
<b>lb/inches</b>						
37,500	3.50	0.50	1.75	14.88	3.05	5/16-18
50,000	3.74	0.50	1.61	14.88	3.74	5/8-16
<b>kg/mm</b> (conversion of above dimensions)						
17,009.7	88.9	12.7	44.5	378.0	77.5	5/16-18
22,679.6	95.0	12.7	40.9	378.0	95.0	5/8-16

### SPECIFICATIONS

<b>Full Scale Output</b>	563WS: $2.0 \pm 1\%$ mV/V	<b>Recommended Excitation</b>	10V (15V Maximum)
	563WS30: $3.0 \pm 1\%$ mV/V		<b>Insulation Resistance</b>
<b>Zero Balance</b>	$\pm 0.02$ mV/V	<b>Compensated Temperature Range</b>	-10°C to 50°C / 14°F to 122°F
<b>Non-linearity</b>	$< \pm 0.023\%$	<b>Safe Overload</b>	150% of full scale
<b>Repeatability</b>	$< \pm 0.023\%$	<b>Breaking Overload</b>	300% of full scale
<b>Hysteresis Error</b>	$< \pm 0.023\%$	<b>Seal Type / IP Rating</b>	Environmentally Sealed / IP67
<b>Creep in 30 min.</b>	$< \pm 0.030\%$	<b>Cable Color Code</b>	Exc+ Red      Exc- Black
<b>Input Resistance</b>	$350 \Omega \pm 7$		Sig+ Green    Sig- White
<b>Output Resistance</b>	$350 \Omega \pm 3$		Shield Bare
<b>Element Material</b>	2Cr13 Stainless Steel		

### PART NUMBER

Rated Capacity	Part No.	Shipping Weight (kg) Approx.
1.25Klb.....	563WS-1.25Klb-YZ.....	2.0
2.5Klb.....	563WS-2.5Klb-YZ.....	3.0
5Klb.....	563WS-5Klb-YZ.....	6.0
10Klb.....	563WS-10Klb-YZ.....	7.0
25Klb.....	563WS-25Klb-YZ.....	15.5
37.5Klb.....	563WS30-37.5Klb-YZ.....	15.5
50Klb.....	563WS30-50Klb-YZ.....	18.0

### INTERCHANGEABLE PRODUCTS

Manufacturer	Model	Part No.	Anyload Part No.
Avery Weigh-Tronix.....	Weigh Bar.....	14702.....	563WS-1.25Klb-YZ
	Weigh Bar.....	14703.....	563WS-2.5Klb-YZ
	Weigh Bar.....	13798.....	563WS-5Klb-YZ
	Weigh Bar.....	13851.....	563WS-10Klb-YZ
	Weigh Bar.....	18834.....	563WS-25Klb-YZ
	Weigh Bar.....	17604.....	563WS-25Klb-YZ
	Weigh Bar.....	18824.....	563WS30-37.5Klb-YZ
Rice Lake.....	RL7500SS	50104.....	563WS30-50Klb-YZ