



OCSG Series

FEATURES

- Fast resolution switching
- 30mm 5 digits LED display
- Fixed hook
- Idle mode to maximize the battery life
- HOLD function
- Tare In / Tare Out
- Unit switch: kg / lb
- Auto overload alarm at 100%F.S. +9e
- Auto power-off function

OPTION

- Wireless Scoreboard

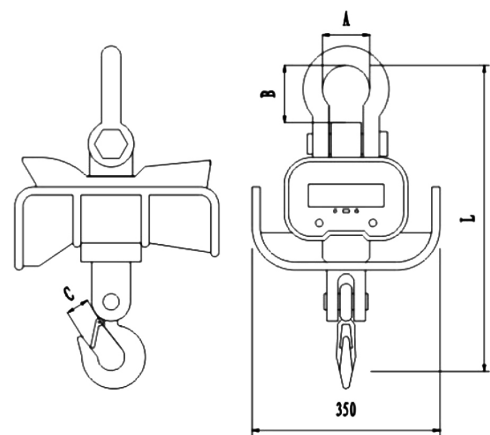

Model	OCSG1
Type	Heat Resistant
Accuracy Class	OIML III
Enclosure	Die-casting Aluminum
Display	30mm LED
Capacity Available	2 / 4 / 6 / 10 / 20 Klb
Battery Life	100 Hours
High Quality Load Receptor	Alloy Steel
Shackle	H.D. Bow
Hook	H.D. Eye
High Capacity Rechargeable Battery	Yes 6V/10Ah
Infrared Remote Control	Yes

Rated Capacity	Division	A	B	C	L	N.W.	G.W.
1t / 2Klb	0.5kg / 1 lb	55mm / 2.17"	65mm / 2.56"	35mm / 1.38"	420mm / 16.54"	16kg / 35.3 lb	--
2t / 4Klb	1kg / 2 lb	72mm / 2.83"	80mm / 3.15"	45mm / 1.77"	600mm / 23.62"	18kg / 39.7 lb	--
3t / 6Klb	1kg / 2 lb	92mm / 3.62"	100mm / 3.94"	55mm / 2.17"	730mm / 28.74"	33kg / 72.8 lb	36kg / 79.4 lb
5t / 10Klb	2kg / 5 lb	98mm / 3.86"	125mm / 4.92"	70mm / 2.76"	850mm / 33.46"	46kg / 101.4 lb	59kg / 130.1 lb
10t / 20Klb	5kg / 10 lb	130mm / 5.12"	140mm / 5.51"	70mm / 2.76"	900mm / 35.43"	64kg / 141.1 lb	69kg / 152.1 lb
15t / 30Klb	5kg / 10 lb	130mm / 5.12"	160mm / 6.30"	75mm / 2.95"	950mm / 37.40"	70kg / 154.3 lb	85kg / 187.4 lb

*Dimensions and specifications are subject to change without notice.