

NPS Series

FEATURES

- Include all universal hand pallet truck functions
- Specialized nylon or polyurethane wheels
- Six 1-inch digits LED display
- Basic counting function
- kg/lb conversion function
- Rechargeable battery
- Low voltage indication
- Auto-off and charging auto control function
- RS232 Output



OPTION

- Stainless Steel Structure
- Printer

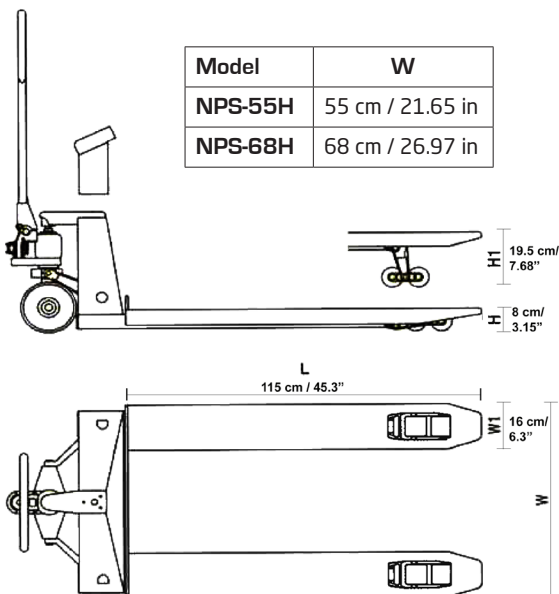

Part#	NPS-68H-5Klb	NPS-55H-5Klb
Division	1 lb	1 lb
Display Size	6x1-inch LED Display	
Fork Width	26.97 in / 68.5 cm	21.65 in / 55.0 cm
Platform Material	Mild Steel	
Scale Dimension	26.97 in X 61 in X 44.1 in / 68.5 cm X 155 cm X 112 cm	
Enclosure	Mild Steel	
Net Weight	203.3 lb / 92.2kg	
Power Source	Rechargeable 6V/4Ah Battery	
Operating Temp.	0 - 45°C / 32 - 113 °F	
Overload Capacity	FS+9e	
Stable Time	1 second	
Pieces per Carton	1	
Gross Weight	124.3kg / 274 lb	124.3kg / 274 lb
Wooden Box Carton Dimensions	64 in x 29 in x 23 in / 113 cm x 74 cm x 59 cm	63 in x 24 in x 23 in / 159 cm x 62 cm x 59 cm
Replacement Load cell	563YHTH	
Legal-for-trade	No	
Warranty	1 Year Limited	

OTHERS

*Dimensions and specifications are subject to change without notice.