

363RSM1

Stainless Steel



Features:

- Assembles: 363RS compression load cell
- Capacities: 500kg-10t
- Self-checking with anti-lifting protection
- Rocker pin design allows for multi-directional movements
- Equipped with jacking bolts
- Equipped with lateral stops

Load Cell Certifications:



Load Cell Not Included.

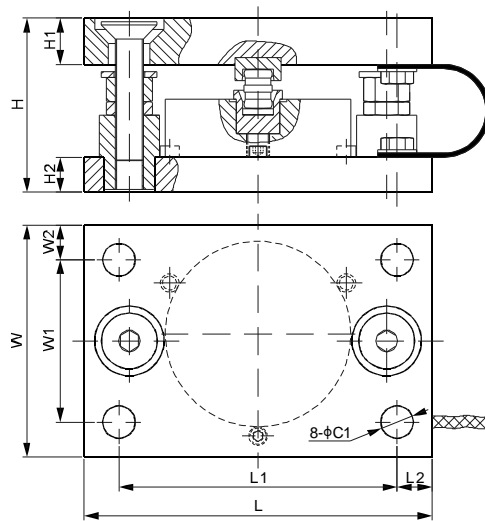

DIMENSIONS

LOAD CELL CAPACITY	C1	H	H1	H2	L	L1	L2	W	W1	W2
kg/mm										
500-1,000	14.0	75.0	20.0	15.0	150.0	120.0	15.0	100.0	70.0	15.0
2,000-5,000	16.0	100.0	20.0	20.0	160.0	120.0	20.0	110.0	70.0	20.0
10,000	18.0	110.0	30.0	20.0	210.0	175.0	17.5	120.0	85.0	17.5
lb/inches (conversion of above dimensions)										
1,102-2,205	0.55	2.95	0.79	0.59	5.91	4.72	0.59	3.94	2.76	0.59
4,409-11,023	0.63	3.94	0.79	0.79	6.30	4.72	0.79	4.33	2.76	0.79
22,046	0.71	4.33	1.18	0.79	8.27	6.89	0.69	4.72	3.35	0.69

PART NUMBER

Load Cell Capacity	Part No.	Shipping Weight (kg) Approx.
500kg-1t.....	363RSM1-(0.5-1)t.....	4.5
2t-5t.....	363RSM1-(2-5)t.....	6.0
10t.....	363RSM1-10t.....	10.5

INTERCHANGEABLE PRODUCTS

Manufacturer	Model
Mettler-Toledo.....	Ringmount 0970
Vishay Revere Transducers.....	RLC Mount