

Features:

- Assembles: 101NH S-beam load cell
- Capacities: 50lb-20Klb
- Load cell is isolated from stray currents
- Allows for high accuracy tension loading
- Equipped with clevis mounts with nylon insulation washers and Teflon ball joint rod ends

Load Cell Certifications:



Load Cell Not Included.

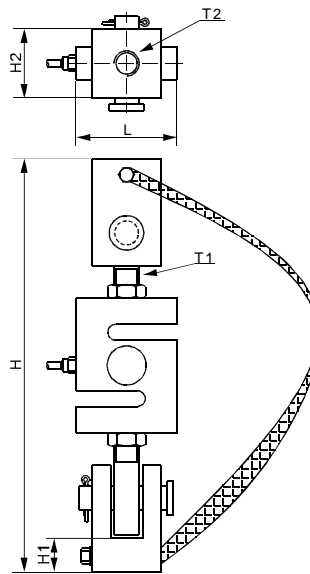

DIMENSIONS

LOAD CELL CAPACITY	H	H1	H2	L	T1	T2
lb/inches						
50 - 250	7.00	0.75	1.55	2.00	1/4 - 28 UNF - 2B	1/2 - 13 UNC - 2B
500 - 3,000	9.50	1.00	2.80	2.00	1/2 - 20 UNF - 2B	3/4 - 10 UNC - 2B
5,000 - 10,000	12.25	1.00	2.80	3.00	3/4 - 16 UNF - 2B	3/4 - 10 UNC - 2B
15,000	18.00	1.75	3.60	3.50	1 - 14 UNS - 2B	1 - 1/2 - 6 UNC - 2B
20,000	20.00	1.75	3.60	4.50	1 - 1/4 - 12 UNF - 2B	1 - 1/2 - 6 UNC - 2B
kg/mm (conversion of above dimensions)						
22.7 - 136.1	177.8	19.1	39.4	50.8	1/4 - 28 UNF - 2B	1/2 - 13 UNC - 2B
226.8 - 1,360.8	241.3	25.4	71.1	50.8	1/2 - 20 UNF - 2B	3/4 - 10 UNC - 2B
2,268 - 4,535.9	317.5	25.4	71.1	76.2	3/4 - 16 UNF - 2B	3/4 - 10 UNC - 2B
6,803.9	457.2	44.5	91.4	88.9	1 - 14 UNS - 2B	1 - 1/2 - 6 UNC - 2B
9,071.8	508.0	44.5	91.4	114.3	1 - 1/4 - 12 UNF - 2B	1 - 1/2 - 6 UNC - 2B

PART NUMBER

Load Cell Capacity	Part No.	Shipping Weight (kg) Approx.
50lb-250lb.....	101NHM1-(50-250)lb	2.6
500lb-3Klb	101NHM1-(0.5-3)Klb.....	2.8
5Klb-10Klb	101NHM1-(5-10)Klb.....	3.2
15Klb.....	101NHM1-15Klb	13.0
20Klb.....	101NHM1-20Klb	13.3

INTERCHANGEABLE PRODUCTS

Manufacturer	Model
Rice Lake.....	ITCM

www.anyloadgroup.com

© 2014 ANYLOAD V1 • dimensions and specifications subject to change with out notice