

## OCSG Series



### FEATURES

- Fast resolution switching
- 30mm 5 digits LED display
- Fixed hook
- Idle mode to maximize the battery life
- HOLD function
- Tare In / Tare Out
- Unit switch: kg / lb
- Auto overload alarm at 100%F.S. +9e
- Auto power-off function

CRANE SCALE

<b>Model</b>	<b>OCSG1</b>
<b>Type</b>	Heat Resistant
<b>Accuracy Class</b>	OIML III
<b>Enclosure</b>	Die-casting Aluminum
<b>Display</b>	30mm LED
<b>Capacity Available</b>	6 / 10 / 20 / 30Klb
<b>Battery Life</b>	100Hours
<b>High Quality Load Receptor</b>	Alloy Steel
<b>Shackle</b>	H.D. Bow
<b>Hook</b>	H.D. Eye
<b>High Capacity Rechargeable</b>	Yes
<b>Battery</b>	6V/10Ah
<b>Infrared Remote Control</b>	Yes

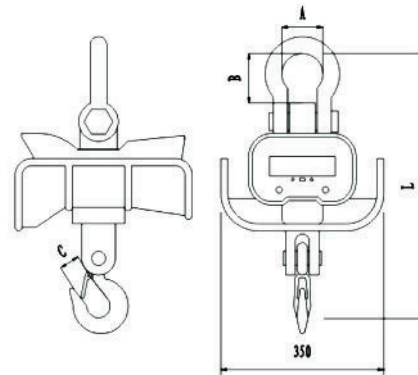

Rated Capacity	Division	A	B	C	L	N.W.	G.W.
6Klb	1kg / 2lb	92mm/3.62"	100mm/3.94"	55mm/2.17"	730mm/28.74"	33kg/72.8lb	36kg/79.4lb
10Klb	2kg / 5lb	98mm/3.86"	125mm/4.92"	70mm/2.76"	850mm/33.46"	46kg/101.4lb	59kg/130.1lb
20Klb	5kg / 10lb	130mm/5.12"	140mm/5.51"	70mm/2.76"	900mm/35.43"	64kg/141.1lb	69kg/152.1lb
30Klb	5kg / 10lb	130mm/5.12"	160mm/6.30"	75mm/2.95"	950mm/37.40"	70kg/154.3lb	85kg/187.4lb

\*Dimensions and specifications are subject to change without notice.