

# RAMP-17

## Floor Scale Ramp

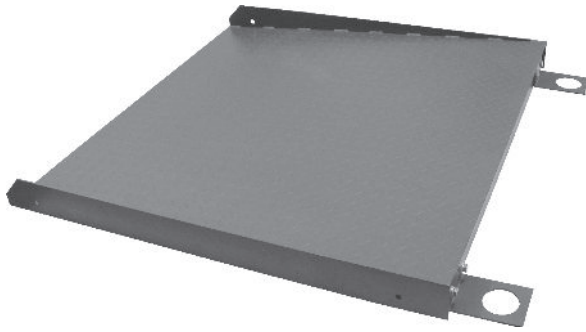

### Features:

- Mild steel construction
- Rugged checker plate surface
- Surface coated with high quality industrial paint
- Includes removable L-shape base mounting plates with connecting nuts and bolts

### RAMP Includes:

- 1 piece x ramp
- 2 pieces x L-shape base mounting plates (item code: BG-P80)
- 4 pieces x M10X30mm nuts and bolts

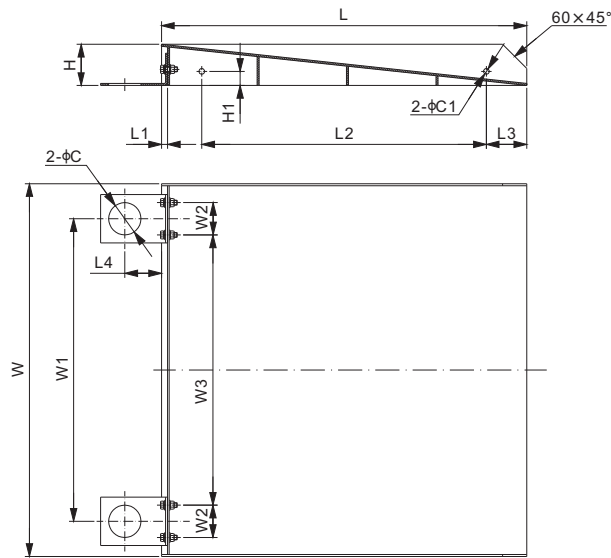

### DIMENSIONS

PART NUMBER	C	C1	H	H1	L	L1	L2	L3	L4	W	W1	W2	W3	Weight (kg) Approx.
<b>inches</b>														
RAMP3×3-17	3.15	0.55	4.02	1.37	35.67	0.59	27.80	3.93	3.62	36.38	29.53	3.15	26.38	50.9
RAMP3×4-17	3.15	0.55	4.02	1.37	47.76	0.59	39.37	4.13	3.62	36.38	29.53	3.15	26.38	-
RAMP4×3-17	3.15	0.55	4.02	1.37	35.67	0.59	27.80	3.93	3.62	48.39	41.50	3.15	38.35	61
RAMP4×4-17	3.15	0.55	4.02	1.37	47.76	0.59	39.37	4.13	3.62	48.39	41.50	3.15	38.35	81
RAMP5×3-17	3.15	0.55	4.02	1.37	35.67	0.59	27.80	3.93	3.62	59.45	52.56	3.15	49.41	-
RAMP5×4-17	3.15	0.55	4.02	1.37	47.76	0.59	39.37	4.13	3.62	59.45	51.18	3.15	48.03	103
<b>mm (conversion of above dimensions)</b>														
RAMP3×3-17	80	14	102	35	906	15	706	100	92	924	750	80	670	50.9
RAMP3×4-17	80	14	102	35	1213	15	1000	105	92	924	750	80	670	-
RAMP4×3-17	80	14	102	35	906	15	706	100	92	1229	1054	80	974	61
RAMP4×4-17	80	14	102	35	1213	15	1000	105	92	1229	1054	80	974	81
RAMP5×3-17	80	14	102	35	906	15	706	100	92	1510	1335	80	1255	-
RAMP5×4-17	80	14	102	35	1213	15	1000	105	92	1510	1300	80	1220	103