

NPS Series

FEATURES

- Include all universal hand pallet truck functions
- Specialized nylon or polyurethane wheels
- Six 1-inch digits LED display
- Basic counting function
- kg/lb conversion function
- Rechargeable battery
- Low voltage indication
- Auto-idle and charging auto control function

OPTION

- Stainless Steel Structure (NPS-55S)
- Printer



NPS-55S Body made with high quality 304 stainless steel

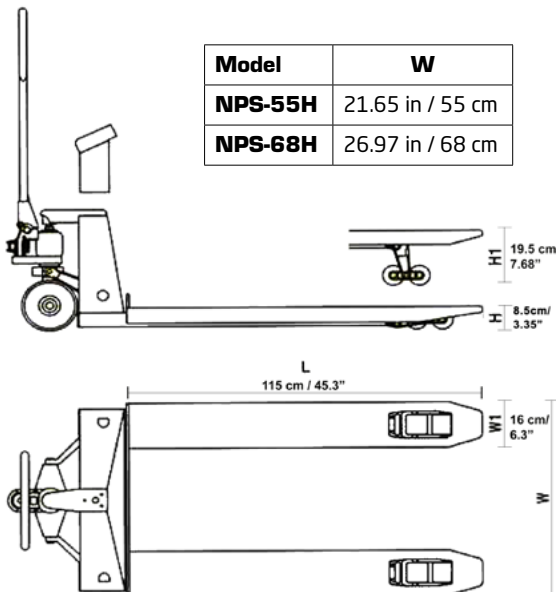

Part#	NPS-68H-5Klb	NPS-55H-5Klb
Division	0.5kg (1.1 lb)	0.5kg (1.1 lb)
Display Size	6x1-inch LED Display	
Fork Width	26.97 in / 68.5 cm	21.65 in / 55.0 cm
Platform Material	Mild Steel	
Scale Dimensions	27 in X 61 in X 44 in / 68.5 cm X 155 cm X 112 cm	27 in X 61 in X 44 in / 68.5 cm X 155 cm X 112 cm
Enclosure	Mild Steel	
Net Weight	203.3 lb / 92.2kg	
Power Source	Rechargeable 6V/4Ah Battery	
Operating Temp.	0 - 45°C / 32 - 113 °F	
Overload Capacity	FS+9e	
Stable Time	1 second	
Wooden Box	1	
Gross Weight	278 lb / 126kg	267 lb / 121kg
Replacement Load cell	563YHTH-1t	
Legal-for-trade	No	
Warranty	1 Year Limited	
Individual Dimensions	63.4 in x 28.7 in x 19.3 in / 161 cm x 73 cm x 49 cm	63.4 in x 23.2 in x 23.2 in / 161 cm x 59 cm x 59 cm
Individual Gross Weight	278 lb / 126kg	267 lb / 121kg
Pieces Per Carton	1	1

*Dimensions and specifications are subject to change without notice.