

ANYLOAD®

PS805

Thermal Receipt Printer

User's Manual (V1611)



Anyload Transducer Co. Ltd

Website: www.anyload.com

Email: info@anyload.com

Fax: +1 866 612 9088

North America Toll Free: 1-855-ANYLOAD (269 5623)

TABLE OF CONTENTS

1. Introduction	2
2. Safety Notice	2
3. Main Features	3
4. Before You Start	3
4.1 Checking What's in the Box	3
4.2 Learn About the Printer	4
4.2 Connecting the Printer	4
5. Maintenance	6
5.1 Cleaning the Printer Head	6
5.2 Cleaning the Paper Scraps	7
6. Operating the Printer	8
6.1 Turn the Printer On or Off	8
6.2 Keys & Indicator on front panel	8
6.3 Error Signal	9
6.4 Printing & Tear off Position	9
7. Specifications	10
8. Communication Interface	10
8.1 Printer	10
8.2 Connect to 805TS/805BS indicator	12

1. Introduction

Thank you for choosing the Anyload PS805 Thermal Receipt Printer. This thermal printer works with Anyload 805BS and 805TS general purpose weighing indicators. User friendly plug and play, low-noise thermal printing, easy paper roll installation, easy paper jam clearance, easy maintenance for tasks such as head cleaning and thermal line printing method.

This manual provides the user's guide in using the product, safety, installation and operation.

2. Safety Notice

- * Read this manual before operate and/or connect the printer.
- * Don't touch the printer head with hard objects.
- * Don't touch the cutter blade.
- * Don't bend the power cord excessively or place any heavy objects on it
- * When connecting or disconnecting the plug, always hold the plug, not the cord.
- * Keep the printer out of children's reach.
- * Use only approved accessories and do not try to disassemble, repair or remodel it.
- * Place the printer on a stable surface. Choose firm, level surface to avoid vibration.
- * Don't let water or other foreign objects go inside the printer.
- * Don't connect a telephone line into the peripheral drive connector.
- * We suggest you unplug the printer from the power outlet if not in use for a long period.
- * If there is a paper jam, switch off and unplug the printer, wait for 10 seconds to let the printer head cool down before remove the paper.
- * Do not place in a humid and/or dusty environment.
- * Only use appropriate paper roll.
- * Don't use paper rolls with end-of-roll glued on the reel. The printer might not able to track the end and might damage the printer.
- * Don't use paper rolls without reel either. It might cause paper jam due to not enough weight when running close to the end of the roll.

3. Main Features

- * Plug-and-play, user friendly.
- * Low-noise thermal printing.
- * Easy paper-roll installation.
- * Easy paper jam clearance.
- * Easy maintenance for tasks such as head cleaning

4. Before You Start

4.1 Checking What's in the Box



PS805 Thermal Receipt Printer



User Manual



Power Cable



Power Adapter



Interface Cable

4.2 Learn About the Printer

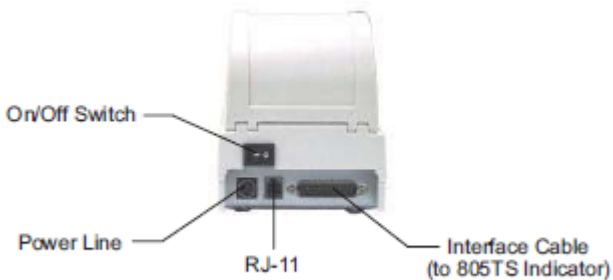
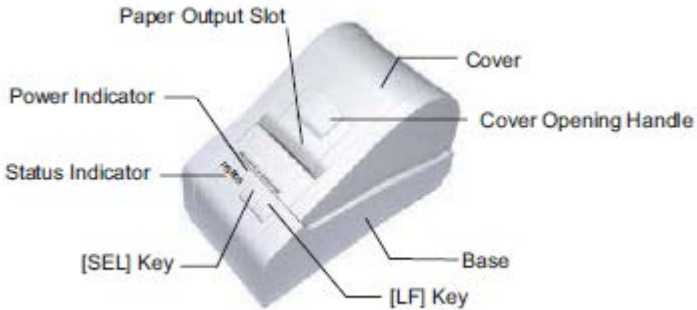

4.3 Connecting the Printer

4.3.1 Connect the cables

Please make sure the power cord is unplugged and the computer connected with the interface cable is turned off



Connect the Power Cable



Connect the Interface Cable

4.3.2 Install Paper Roll



Open the top cover
by lifting the handle



Place the thermal paper roll
as shown in the above figure



The Printer won't work probably
if you reversed the paper roll



Close the cover firmly
then press the [SEL] key
to make it on-line

Note:

- * Only use high quality thermal paper roll with appropriate size and specification.
- * Paper roll that is too wide or too narrow might cause paper jam.
- * Use low quality thermal paper roll might result in poor print out and/or reduce the life of the printer head.
- * Don't press the [LF] key when out of paper to prevent damage to the printer head.
- * Don't pull the paper out by hand.
- * Please close the top cover gently.

5. Maintenance

5.1 Cleaning the Printer Head

After using the printer for a period of time, the print out might be fade or not clear. In this case, a clean up maintenance is required.

1. Please make sure the power cord is unplugged and the interface cable is disconnected.
2. Open the top cover, remove the paper roll from the printer.
3. Wait for 10 seconds to let the printer head cool down naturally.
4. Use a cotton swab, dip with alcohol and wipe the printer head gently.
4. Wait until the alcohol on the printer head completely evaporated, reload the thermal paper roll, close the cover and reconnect all cables.
5. Check if the print out has improved.
6. Repeat the above steps if necessary. If the problem persist



Never use sand paper, cutter, screw driver or any hard object to scratch the printer head to prevent permanent damage to the printer head

5.2 Cleaning the Paper Scraps

After using the printer for a period of time, paper scraps will accumulate around the printer head area. Paper scraps felt into the gears might result in damaging the gear system. Therefore, regular clean up is required.

1. Please make sure the power cord is unplugged and the interface cable is disconnected.
2. Use a soft brush to clean up paper scraps around the cutter blade.
3. Open the top cover, remove the paper roll from the printer.
4. Use air brush to blow away the paper scraps on the gear system. Use soft brush to remove paper scraps around the printer head.

Note:

* Recommend to do the paper scraps clean up twice a month. If using low quality thermal paper roll and/or using the printer very often, can process the clean procedure more frequently

5.3 Handling the Printer



Use both hand to hold the base



Never lift by holding the top cover

6. Operating the Printer

6.1 Turn the Printer On or Off

After the power cable are plugged in and connected with the power adapter. The printer can be turn on or off by the switch at the back



6.2 Keys & Indicators on Front Panel

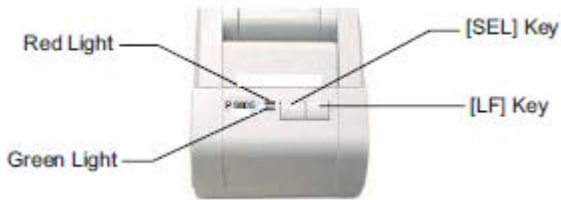

On/Off-line: Switch on or off by pressing the [SEL] key once.

On-line: Green indicator light is on.

Off-line: Green indicator light is off. Printer will not accept any data. Press [LF] key will run the paper.

Power On: Red indicator light is on.

Power Off: Red indicator light is off

6.3 Error Signal

A flashing green light on the front panel is an error signal. The flashing frequency indicates different error message:

Signal	Error Message	Suggestion
---	Out of paper	Replace paper roll.
---.---	Printer head over heat	Wait until temperature of printer head drop to 45 C, will resume automatically.
---.---.---	Thermal printer head resistance error	Non-recoverable. Please send for repair. Usually due to cable connection error.

6.4 Printing & Tear off Position

The distance between the tear off position and the printing position is 12mm

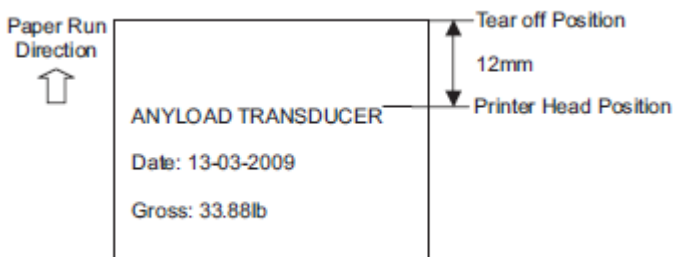

7. Specifications

Print Method:	Thermal Line Printing
Paper Roll Width:	57.5 +/- 0.5mm
Paper Roll Diameter:	Max. 50mm; Min. Φ13mm (w/reel)
Paper Thickness:	60~70um; 53~60g/m
Effective Print Width:	48mm
Print Density:	8 pt/mm; 384 pt/line
Print Speed:	50mm/second
Paper Rolling Speed:	50mm/second
Printer Power Input:	DC9~12V, 2A
Working Environment:	0~50°C; Dampness 20~85% (When 34°C, Humidity 85%) (When 40°C, Humidity 58%)
Storage Environment:	-20~60°C; Dampness 5~95%
Reliability (MCBF):	10 X 10 Line
Printer Net Weight:	1.0Kg
Dimensions:	116 (W) X 185 (D) X 140 (H) mm

8. Communication Interface

8.1 Printer

- RS232C comparable
- Support RTS/CTS and XON/XOFF
- 25-pin female D

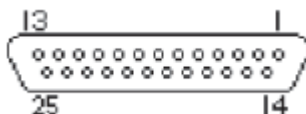

Pin	Signal	Source	Description
3	RXD	Computer	Printer receive data from computer.
2	TXD	Printer	When requesting printer status command, printer transmit status signal to computer.
4	RTS	Printer	"MARK" = printer busy, cannot receive data; "SPACE" = ready, can receive data.

7	GND	—	Ground
---	-----	---	--------

PS805 printer can connect with standard RS232C with PC

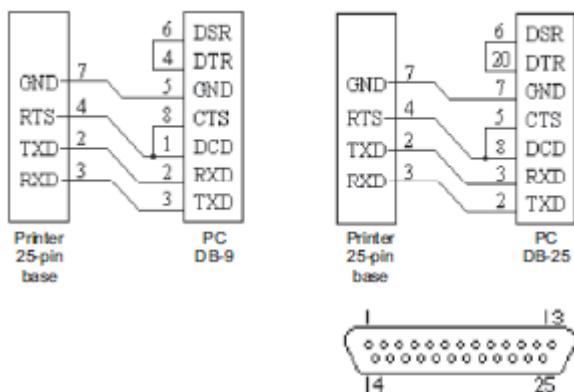

<u>Pin</u>	<u>Signal</u>	<u>Direction</u>	<u>Description</u>
1	/STB	In	
2	Data1	In	
3	Data2	In	
4	Data3	In	
5	Data4	In	
6	Data5	In	
7	Data6	In	
8	Data7	In	
9	Data8	In	
10	/ACK	Out	
11	BUSY	Out	
12	PE	Out	
13	SEL	Out	
14	NC	—	
15	/ERR	Out	
16-17	NC	—	
18-25	GND	—	

8.2 Connect to 805TS/805BS Indicator

