

# 805TS INDICATOR MANUAL



**ANYLOAD**

[www.load-cell.com](http://www.load-cell.com)

<b>1. Introduction</b> .....	<b>1</b>
<b>1.1 Operation Modes</b> .....	<b>1</b>
<b>1.2 Front Panel Keypad</b> .....	<b>2</b>
<b>1.3 Indicating Lights</b> .....	<b>2</b>
<b>1.4 Start Up</b> .....	<b>3</b>
<b>1.5 Operations</b> .....	<b>3</b>
<b>1.5.1 Normal Weighing Mode</b> .....	<b>3</b>
<b>1.5.1.1 Gross/Net Mode</b> .....	<b>3</b>
<b>1.5.1.2 Units</b> .....	<b>3</b>
<b>1.5.1.3 Zero Scale</b> .....	<b>3</b>
<b>1.5.1.4 Acquire Tare</b> .....	<b>4</b>
<b>1.5.1.5 Remove Stored Tare Value</b> .....	<b>4</b>
<b>1.5.1.6 Print</b> .....	<b>4</b>
<b>1.5.2 Peak Mode Operations</b> .....	<b>4</b>
<b>1.5.2.1 Units</b> .....	<b>4</b>
<b>1.5.2.2 Peak/Normal Weighing Mode</b> .....	<b>4</b>
<b>1.5.2.3 Remove Peak Mode Value</b> .....	<b>4</b>
<b>1.5.2.4 Zero Scale</b> .....	<b>5</b>
<b>1.5.2.5 Print</b> .....	<b>5</b>
<b>1.5.3 Count Mode Operations</b> .....	<b>5</b>
<b>1.5.3.1 Gross/Net Mode</b> .....	<b>5</b>
<b>1.5.3.2 Units</b> .....	<b>5</b>
<b>1.5.3.3 Zero Scale</b> .....	<b>5</b>
<b>1.5.3.4 Acquire Tare</b> .....	<b>5</b>
<b>1.5.3.5 Remove Stored Tare Value</b> .....	<b>6</b>
<b>1.5.3.6 Input Item Code</b> .....	<b>6</b>
<b>1.5.3.7 Fast Setup of Count Items Average Weight</b> .....	<b>6</b>
<b>1.5.3.8 Print</b> .....	<b>7</b>
<b>2. Wire Installation</b> .....	<b>7</b>
<b>2.1 DC : DC power supply</b> .....	<b>7</b>
<b>2.2 K1 Switch</b> .....	<b>7</b>
<b>2.3 KOUT : Relay signal outputs</b> .....	<b>8</b>
<b>2.4 K3 : Output:RS485/RS232</b> .....	<b>8</b>
<b>2.5 Load Cell Input</b> .....	<b>8</b>
<b>2.6 COMM : Serial Communication port (see Fig. 2-1)</b> .....	<b>8</b>
<b>3. Configuration</b> .....	<b>8</b>
<b>3.1 Front Panel Configuration</b> .....	<b>9</b>
<b>3.2 Menu Structure and Parameter Descriptions</b> .....	<b>9</b>
<b>3.2.1 F1(Configuration) Menu</b> .....	<b>11</b>

3.2.2 F2(Format) Menu.....	14
3.2.3 F3(Calibration) Menu .....	15
3.2.4 F4(Serial) Menu .....	16
3.2.5 F5(Mode) Menu .....	17
3.2.6 F6(Relay) Menu .....	19
3.2.7 F7(Ver) Menu .....	20
3.2.8 F8(PFormat) Menu .....	22
4. Calibration .....	22
5. Count Items Average Weight Setup .....	24
6. Relay Output Setup.....	26
7. Print Format.....	28
7.1 Print Format Commands .....	28
7.2 GFMT and NFMT Print Format Input .....	29
7.3 Default Formatting .....	31
7.4 Print Consecutive Number .....	31
7.5 Date and Time Setting .....	32
8. Serial Communication .....	33
8.1 Continuous Transmission.....	33
8.2 Transmission Upon Request .....	34
8.2.1 Data Transmission Sequence.....	34
8.2.2 Communication Command .....	36
8.2.2.1 Transmit Current Weight Value .....	36
8.2.2.2 Zero Scale .....	37
8.2.2.3 Print Format Transmission Command .....	37
8.3 Serial Communication Tests.....	38
9. Appendix.....	39
9.1 Error Messages .....	39
9.2 Software Version and Default Configuration Parameters .....	40
9.2.1 Find out indicator software version .....	40
9.2.2 Restore Factory Setup Parameters (Default Configuration Parameters).....	41
9.3 Technical Specifications .....	41
9.4 ASCII Codes Table .....	43
9.5 805TS Display Characters.....	44

This manual provides installation, operation and configuration information of indicator model 805TS. It is recommended to go through the manual in details before installing, operating or configuring the indicator.



*When it is required to work inside the indicator enclosure for some procedures described, the work can only be performed by qualified technical personnel.*

## 1. Introduction

The 805TS digital indicator is a general purpose weight indicator having multi-functions with source of signal coming from load cells.

Key features include:

- Parameter setting and calibration are performed at the front panel
- Auto zero scale can be selected when switching on indicator
- Auto zero tracking
- Unit exchange between kg & lb
- 0.8 in (20mm) in height red LED display and with option for blue LED
- Improper operation and fault indication
- Normal Weighing mode, Peak mode and Count mode functions
- 2 way relay signal output
- Zero Scale, Tare mode, Gross/Net weight selections
- Equipped with RS232C connecting port with options for Data Transmitted Continuously and Data Transmitted Upon Request
- Print functions with programmable print format (with build-in clock to show dates and hours)
- Can drive up to eight 350Ω or sixteen 700Ω load cells

### 1.1 Operation Modes

There are Weighing mode and Configuration mode.

- Weighing Mode

Only when the K1 switch is turned off, indicator can get into Weighing mode.

According to F5.1 Menu, three different Weighing modes can be selected (refer to F5.1 Menu).

- (1) Normal Weighing mode: Indicator displays gross weight or net weight in this mode. Unit of the displayed weight is highlighted by indicator light and different units can be toggled (refer to Section 1.5.1).
- (2) Peak mode: Indicator displays peak value of load acted upon the weighing instrument (refer to Section 1.5.2).
- (3) Count mode: Indicator displays number of weighed items having the same weight (refer to Section 1.5.3).

- Configuration Mode

Only when the K1 switch is turned on, indicator can get into configuration mode.

Most of the operation data setting including parameters setting and weighing range calibration are to be carried out in Configuration mode.

Remove the back panel of indicator (refer to Fig 2-1 Sockets on Circuit Board). Switch on K1 jumper located at the lower corner. Indicator is in Configuration mode and display shows “F1”. Refer to Section 3 for details.

## 1.2 Front Panel Keypad

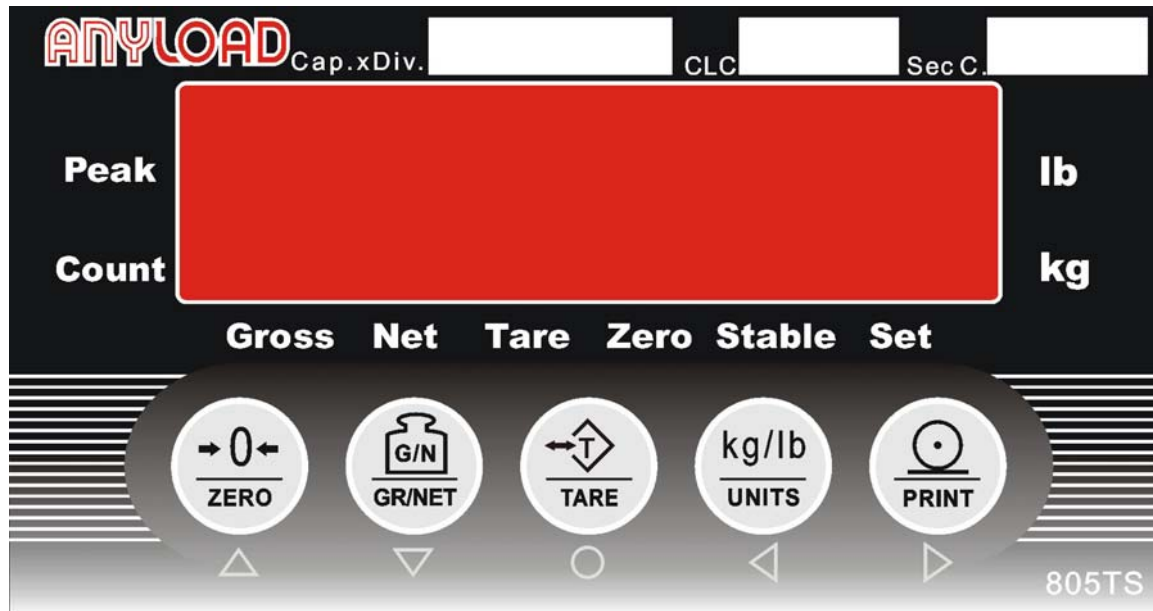

Fig.1-2 Front Panel Configuration

Fig.1-2 shows indicator display, LED indicator lights and keypad configuration. Signs at the bottom of the keypad are for configuration operation use (refer to Section 3 for details).

The signs are for inputting item codes in Count Mode (refer to section 1.5.3.6 for details).

## 1.3 Indicating Lights

- “Peak”—— Light is on when operating in Peak mode.
- “Count”—— Light is on when operating in Count mode.
- “kg”—— Light is on when display showing units in kg.
- “lb”—— Light is on when display showing units in lb.
- “Gross”—— Light is on when display showing gross weight.
- “Net”—— Light is on when display showing net weight.
- “Stable”—— Light is on when load is stable or within the preset dynamic load range (refer to F1.4 Menu for dynamic load setting).

- “Zero”—— Light is on when load is within zero range (<1/4d).
- “Tare”—— Light is on when Tare setting is not zero.

## 1.4 Start Up

Connect power supply. Indicator goes through a self checking process (showing all 0 to all 9, decimal point and indicator lights). Two possible outcomes depending on F1.12 Menu settings :

- If indicator is set to auto Zero Scale (F1.12=0), and the load on the scale is within the zero scale setting in F1.3 Menu, indicator zeros automatically and display shows “0”.
- If indicator is not set to Zero Scale (F1.12=1) or the load exceeds the zero scale setting in F1.3 Menu, display shows actual load.

Refer to F1.3 Menu and F1.12 Menu for further information.

## 1.5 Operations

Indicator goes to Weighing mode when the K1 switch is turned on. It can be selected to normal Weighing mode, Peak mode and Count mode (refer to F5.1 Menu).

### 1.5.1 Normal Weighing Mode

When it is set to the Normal Weighing mode (F5.1=0), “Peak” light and “Count” light are off. Indicator is in Normal Weighing mode (refer to F5.1 Menu)

Basic operations in Normal Weighing mode :

#### 1.5.1.1 Gross/Net Mode

Press **【GR/NET】**, change to net weight from gross weight or vice versa. When tare weight is stored (indicator has stored tare weight value other than 0), net weight shown on the display is equal to gross weight less tare weight.

”Gross” light is on when indicating gross weight.

”Net” light is on when indicating net weight.

#### 1.5.1.2 Units

When parameter F6.1 was set in NTEP, CANADA or NONE mode, press **【UNITS】**, change to kg from lb or vice versa. The corresponding unit light is on.

#### 1.5.1.3 Zero Scale

When in Gross mode (“Gross” light is on), remove the load from scale and wait until the “Stable” light is on. Press **【ZERO】** and “Zero” light is on. Zero Scale setting is complete.

#### **1.5.1.4 Acquire Tare**

When no Tare is stored (“Tare” light is off), place the container on the scale and wait until the “Stable” light is on. Press **【TARE】**. Tare weight is stored. Display shows Net weight while “Net” light is on (refer to F6.1 Menu).

#### **1.5.1.5 Remove Stored Tare Value**

When a tare weight is stored (“Tare” light is on), press **【TARE】** to remove the stored tare value. Display shows gross weight while the “Gross” light is on (refer to F6.1 Menu).

#### **1.5.1.6 Print**

When the “Stable” light is on, press **【PRINT】**. Data from indicator is transmitted to a serial printer for printing. After each printing, the Consecutive Number is increased by 1. Print format is set according to F8 Menu (refer to Section 7 for Print Format).

### **1.5.2 Peak Mode Operations**

Only when F6.1 Menu is set to None mode, F5.1 Menu can be set to Peak mode (F5.1=1), then “Peak” light is on and indicator is in Peak mode (refer to F5.1 Menu setting).

When in Peak mode, display shows gross weight. **【GR/NET】** button is for switching between Peak and Normal Weighing modes. **【TARE】** button is for cancellation of Peak mode.

Basic operations when in Peak mode:

#### **1.5.2.1 Units**

When Peak mode operation is deactivated (“Set” light is off), press **【UNITS】**, displayed unit is changed to kg from lb, or vice versa. Corresponding unit indicating light is on.

When Peak mode operation is activated (“Set” light is on), the **【UNITS】** button does not function.

#### **1.5.2.2 Peak/Normal Weighing Mode**

When “Set” light is on, Peak mode is activated. Display shows the maximum value of load which has been applied to the load cell. When the load is removed, display still shows the peak load.

When “Set” light is off, Peak mode is deactivated. Value shown on display changes according to the load applied to the load cell.

Press **【GR/NET】** can change indicator from Peak mode to Normal Weighing mode, or vice versa.

#### **1.5.2.3 Remove Peak Mode Value**

When Peak mode is on (“Set” light is on), remove the load and press **【TARE】**. Peak mode value is removed, and indicator starts another Peak mode operation.

#### **1.5.2.4 Zero Scale**

When Peak mode is on (“Set” light is on), press **【GR/NET】** to switch indicator to Normal Weighing mode (“Set” light is off).

Remove the load and when the “Stable” light is on, press **【ZERO】**. Display shows zero value.

#### **1.5.2.5 Print**

When Peak mode is on (“Set” light is on), press **【PRINT】** and Peak value is printed. When the Peak mode is off (“Set” light is off), press **【PRINT】** and the current load value is printed. After each printing, the Consecutive Number is increased by 1. The Print format is set according to F8 Menu (refer to Section 7 for Print Format).

### **1.5.3 Count Mode Operations**

Only when F6.1 Menu is set to None mode, F5.1 Menu can be set to Count mode (F5.1=2), then “Count” light is on. Indicator is in the Count mode operations (refer to F5.1 Menu for setting).

Basic operations in Count mode:

#### **1.5.3.1 Gross/Net Mode**

Press **【GR/NET】** to switch between Gross weight to Net weight. When in Tare mode, Net weight is equal to Gross weight less Tare weight.

”Gross” light is on when in Gross mode.

”Net” light is on when in Net mode.

#### **1.5.3.2 Units**

Press **【UNITS】**, switch between the weight of load and the quantity of count items. When showing the weight of load, follow F2.3 Menu to choose the unit (refer to F2.3 Menu). When showing the quantity of count items, display shows “nxxxxx”. xxxxx is the quantity of count items.

#### **1.5.3.3 Zero Scale**

When in Gross mode (“Gross” light is on), remove the load from scale. When the “Stable” light is on, press **【ZERO】** and “Zero” light is on. Zero Scale setting is complete.

#### **1.5.3.4 Acquire Tare**

When no Tare is stored (“Tare” light is off), place the container onto the scale and wait until the “Stable” light is on. Press **【TARE】** and Tare value (weight of container) is stored. Display shows Net weight and the “Net” light is on (refer to F6.1 Menu).



### 1.5.3.5 Remove Stored Tare Value

When a tare value is stored (“Tare” light is on), press **【TARE】** and the stored tare value is removed. Display shows Gross weight and the “Gross” light is on (refer F6.1 Menu).

### 1.5.3.6 Input Item Code

When in Count mode, press **【PRINT】** to go to Input Item Code status. Display shows “P=xx”, where xx is the code number of the current count item and x flashes.

Now the functions of the keypad become  $\triangle$ ,  $\nabla$ ,  $\bigcirc$ ,  $\blacktriangleright$ ,  $\blacktriangleleft$ .  $\blacktriangleright$ ,  $\blacktriangleleft$  are for moving forward and backward while  $\triangle$ ,  $\nabla$  are for increasing and decreasing the digits.

After finish with Input Item Code, press  $\bigcirc$  key if the stored Item Code is not 0. Item Code of the current count items is stored and the keypad returns to normal operating functions as shown in Fig. 1-1.

If the stored Item Code = 0, display goes to the Fast Setup of the Averaging Weight of the Count Item (refer to Section 1.5.3.7).

### 1.5.3.7 Fast Setup of Count Items Average Weight

To obtain the average weight of a count item without going into the Configuration mode, follow the procedure below,

- (1) Enter the Input Item Code according to Section 1.5.3.6. Set the Item Code = 0. Display shows “P = 00”.
- (2) Remove all weights from the scale. Press  $\bigcirc$  to zero the scale. Display shows “CAL” while calibration is in progress.
- (3) After zeroing the scale, display proceeds to Count Items Average Weight Setup. Use  $\blacktriangleleft$ ,  $\blacktriangleright$  to select the suitable sample quantity. Normally select larger quantity for lighter count items.
- (4) After selecting a suitable quantity and placing the respective quantity of count items to the scale, press  $\bigcirc$ . Display shows “CAL” while calibration is in progress. When complete, there are two possible outcomes :
  - Display shows “- - E5 - -” when the average weight of the count items is too small.  
Then there are two options :
    - Combine a few count items to become one count item. Place the same quantity of count items to the scale as per the sample quantity set in (3) above. Press  $\bigcirc$  to calculate the average weight.
    - Press  $\triangle$  to cancel Count Items Average Weight Setup and return to the Weighing mode.
  - Display shows the count items average weight and returns to the Weighing mode.
- (5) After returning to the Weighing mode, keypad functions according to Fig. 1-1.

**Note: During the process (2), (3) and (4) above, turn on the K1 switch to cancel the Count Items Average Weight Setup and return to the Weighing mode.**

### 1.5.3.8 Print

When in Count mode (display shows “nxxxxx”), place the items which are to be counted onto the scale. Wait until the “Stable” light is on and press **【PRINT】**. The quantity of items is printed. After each printing, the Consecutive Number is increased by 1. The printing format is set according to F8 Menu (refer to Section 7 for Print Format).

## 2. Wire Installation

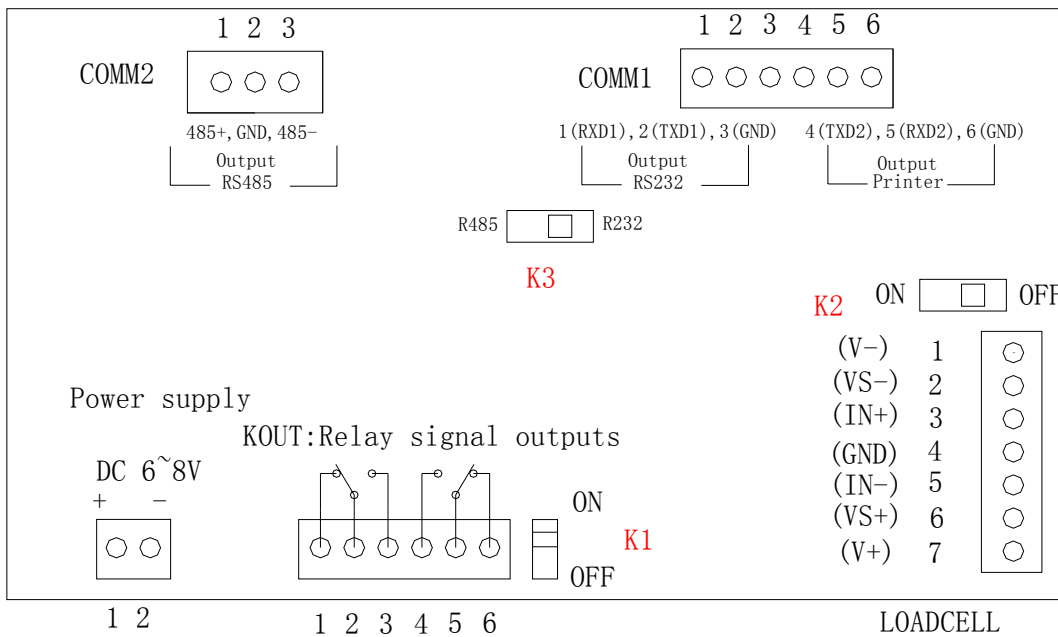

Fig. 2-1 Sockets on Circuit Board

**Note: When connect to 4-wire load cell, please turn K2 switch ON.**

**When connect to 6-wire load cell, please turn K2 switch OFF.**

### 2.1 DC : DC power supply

1 — DC+ ; 2 — DC- ; (6V~8.5V DC/1A)

### 2.2 K1 Switch

K1 switch is used to switch between calibration and normal weighing mode. When it is turned ON, the indicator get into calibration mode, otherwise it is normal weighing mode.

## 2.3 KOUT : Relay signal outputs

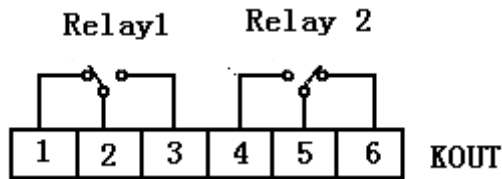

Fig. 2-2 Relay Connection ports

## 2.4 K3 : Output:RS485/RS232

Selectable output by switch K3: RS485/RS232

## 2.5 Load Cell Input

- 1 (V-) — Excitation-
- 2 (VS-) — Sense-
- 3 (IN+) — Signal+
- 4 (GND) — Signal ground
- 5 (IN-) — Signal-
- 6 (VS+) — Sense+
- 7 (V+) — Excitation+

## 2.6 COMM : Serial Communication port (see Fig. 2-1)

- 1 (RXD1) — RS232C Receipt port 1
- 2 (TXD1) — RS232C Output port 1
- 3 (GND) — Signal ground (connect to computer)
- 4 (TXD2) — RS232C Output port 2
- 5 (RXD2) — RS232C Receipt port 2
- 6 (GND) — Signal ground (connect to serial printer).

## 3. Configuration

Configure indicator according to the following steps:

- Remove the back panel of indicator.
- Turn on K1 switch.
- Indicator is now in Configuration mode and display shows “F1” in the first Menu item of Level 1 Submenu.
- When configuration is completed and display shows “F1”, Turn off K1 switch, exit from

Configuration mode.

### 3.1 Front Panel Configuration

When configuring, keypad functions as shown in Fig. 3-1.

Table 3-1 Basic functions of Level 1 Submenu

Menu		Menu Function
F1	Config	Configure grads, zero tracking, zero range, motion band, overload, sample rate, digital filtering and zero scale. See Section 3.2.1.
F2	Format	Set decimal point location, display divisions, display rate and display unit. See Section 3.2.2.
F3	Calibration	Calibrate indicator. See Section 3.2.3 and Section 4.
F4	Serial	Configure serial communication ports. See Section 3.2.4 and Section 8.
F5	Mode	Set weighing mode and unit weight of counted items. See Section 1.5.3, Section 3.2.5 and Section 5.
F6	Relay	Set Relay operation modes. See Section 3.2.6 and Section 6.
F7	Ver	Indicate software version and regenerate default configuration parameters. See Section 3.2.7 and Appendix 9-2.
F8	PFormat	Set print format. See Section 3.2.8 and Section 7.

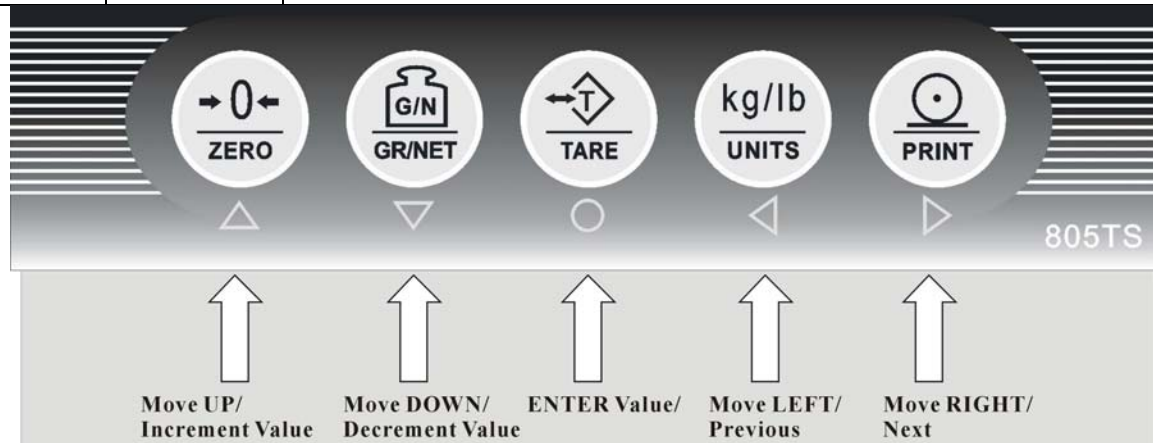

Fig. 3-1 Keypad functions in Configuration Mode

### 3.2 Menu Structure and Parameter Descriptions

Menu structure is shown in the following section in flow diagram. In the actual Menu structure, the selected Menu item is displayed horizontally. In most Menus, set parameters and parameter value are shown in tables. Choices with “√” are default values, and “number”

is editable values.

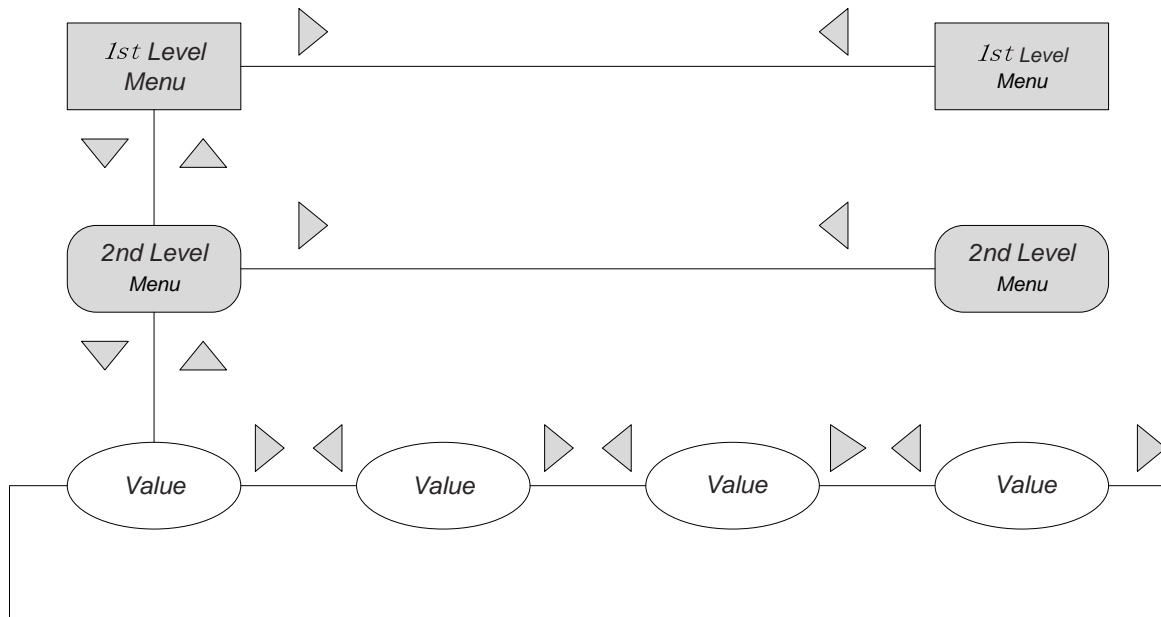

Fig. 3-2 Menu Configuration Flow Diagram

There are 4 directional keys  $\blacktriangleright$ ,  $\blacktriangleleft$ ,  $\blacktriangleup$ ,  $\blacktriangledown$  to be used for configuration operation.  $\blacktriangleright$ ,  $\blacktriangleleft$  are for horizontal movement in the same level menu and parameters.  $\blacktriangleup$ ,  $\blacktriangledown$  are for moving up and down through different level menus.  $\bigcirc$  is for confirming a choice of parameter in a menu.

Use  $\blacktriangleright$ ,  $\blacktriangleleft$  to choose a parameter in a menu and use  $\blacktriangledown$  to move to the next level menu or parameter.

When moving into a parameter of a menu, display shows the previous choice.

When the parameter of a menu is a fixed value, use  $\blacktriangleright$ ,  $\blacktriangleleft$  to move horizontally and use  $\bigcirc$  to store the selected parameter and to return to the last menu.

When a parameter value of a menu is editable as shown in Fig 3-3, directional keys are used to edit the digit selected, and to increase or decrease the value of the selected digit.

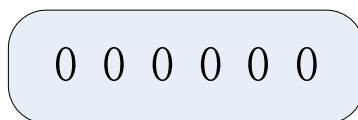

Fig. 3-3 Editable Parameter

### 3.2.1 F1(Configuration) Menu

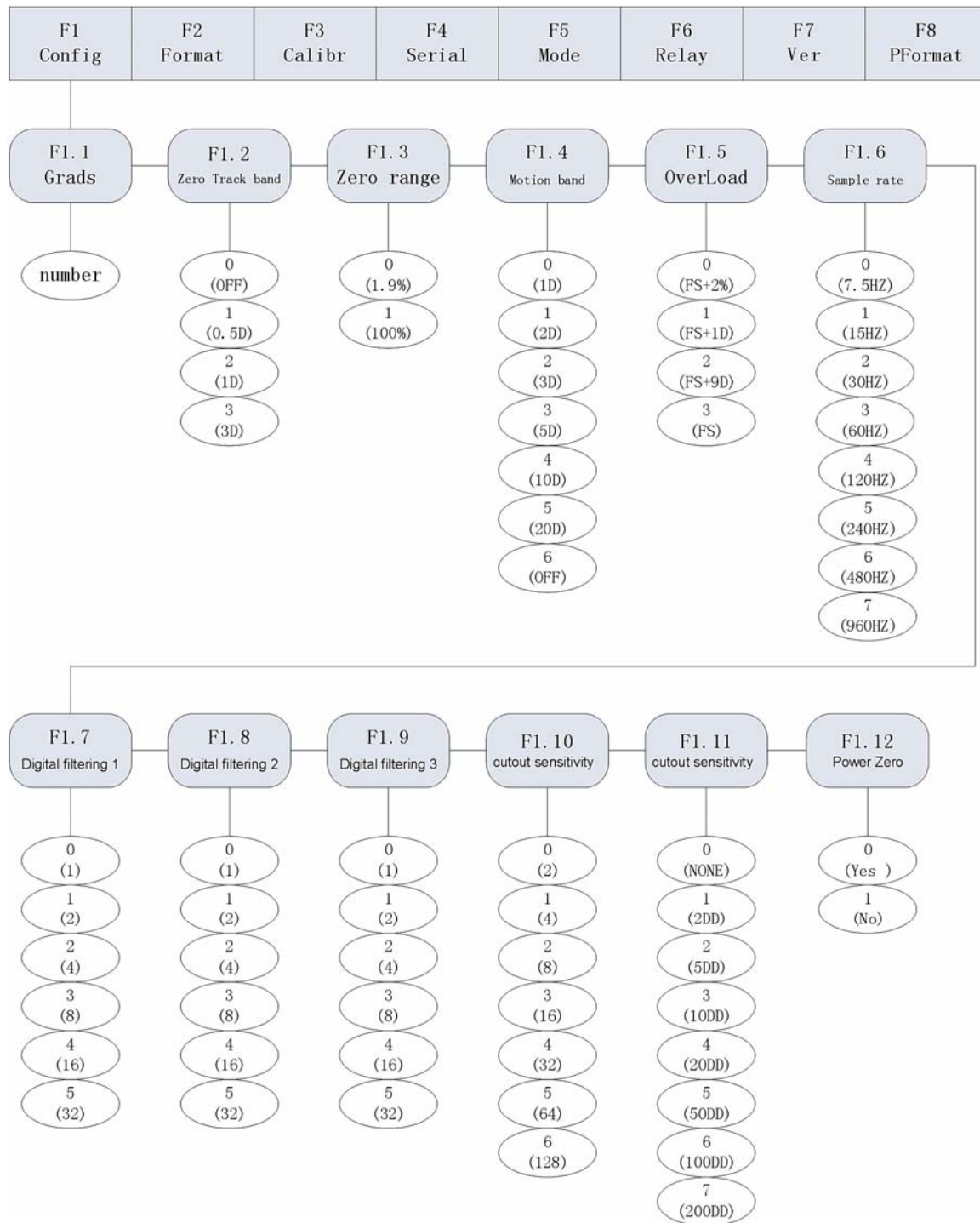

Fig. 3-4 F1 (Configuration) Menu Structure

Table 3-2 F1 (Configuration) Menu Parameters

F1 (Configuration) Menu		
Parameter	Choices	Description
Level 2 Submenu		
F1.1 (Grads)	<i>number</i>	Graduations. Specifies the number of full scale graduations. The value entered must be in the range 1-100 000. Graduation=Capacity/Display Divisions. Display divisions for primary and secondary units are specified in the F2 (Format) Menu.
F1.2 (Zero Track Band)	0 (OFF)	Zero track band. Automatically zeros the scale when within the range specified, as long as the input is within the configured zero range. Selections are $\pm$ display divisions.
	1 (0.5D) $\checkmark$	
	2 (1D)	
	3 (3D)	
F1.3 (Zero Range)	0 (1.9%FS) $\checkmark$	Zero range. Selects the range within which the scale can be zeroed. The 1.9% selection is $\pm 1.9\%$ around the calibrated zero point, for a total range of 3.8% FS. FS=Grads * D
	1 (100%FS)	
F1.4 (Motion Band)	0 (1D) $\checkmark$	Motion band. Sets the level in display divisions at which scale motion is detected. If motion is not detected for 1 second or more, the "Stable" light is on. Some operations, including Zero, Tare and Print, require the scale to be at standstill. When F1.4 is selected OFF, F1.2 should also be set to OFF.
	1 (2D)	
	2 (3D)	
	3 (5D)	
	4 (10D)	
	5 (20D)	
	6 (OFF)	
F1.5 (Overload)	0 (FS+2%)	Overload. Determines the point at which the display shows "OF" indicating the scale is overloaded.
	1 (FS+1D)	
	2 (FS+9D) $\checkmark$	
	3 (FS)	
F1.6 (Sample Rate)	0 (7.5Hz)	Sample rate. Selects the measurement rate in samples per second of the analogue-to-digital converter. Lower sample rate values provide greater signal noise immunity.
	1 (15Hz) $\checkmark$	
	2 (30Hz)	
	3 (60Hz)	
	4 (120Hz)	
	5 (240Hz)	
	6 (480Hz)	
	7 (960Hz)	
	0	Digital Filter. Selects the digital filtering rate. The

F1.7 (Digital Filter 1)	1√	higher the value, the lower is the effect acting upon the indicator due to noise and mechanical vibration and hence having a more accurate display. However, it slows down the settling rate of the indicator.
	2	
	3	
	4	
	5	
F1.8 (Digital Filter 2)	0	
	1	
	2√	
	3	
	4	
F1.9 (Digital Filter 3)	5	
	0	
	1	
	2√	
	3	
F1.10 (Digital filter cutout sensitivity)	4	
	5	
	0 (2OUT)	Digital Filter Cutout Sensitivity. Specifies the number of consecutive readings that must fall outside the filter threshold (the value set for F1.11) before digital filtering is suspended. The higher the value, the lower is the effect due to noise and mechanical vibration and hence having a more accurate display.
	1 (4OUT) √	
	2 (8OUT)	
3 (16OUT)		
4 (32OUT)		
5 (64OUT)		
6 (128OUT)		
F1.11 (Digital filter cutout threshold)	0 (NONE)	Digital Filter Cutout Threshold. Specifies the filter threshold, in display divisions. When a specified number of consecutive scale readings (the value set for F1.10) fall outside of this threshold, digital filtering is suspended. Digital filtering continues to function when F1.11 is set to 0 (NONE).
	1 (2D)	
	2 (5D) √	
	3 (10D)	
	4 (20D)	
	5 (50D)	
	6 (100D)	
F1.12 (Power Up Zero)	7 (200D)	
	0 (Yes) √	Power Up Zero. Specifies whether to zero the scale when switching on the scale. When selected 0 (Yes), indicator zeros the scale after finishing self checking.
1 (No)		



### 3.2.2 F2(Format) Menu

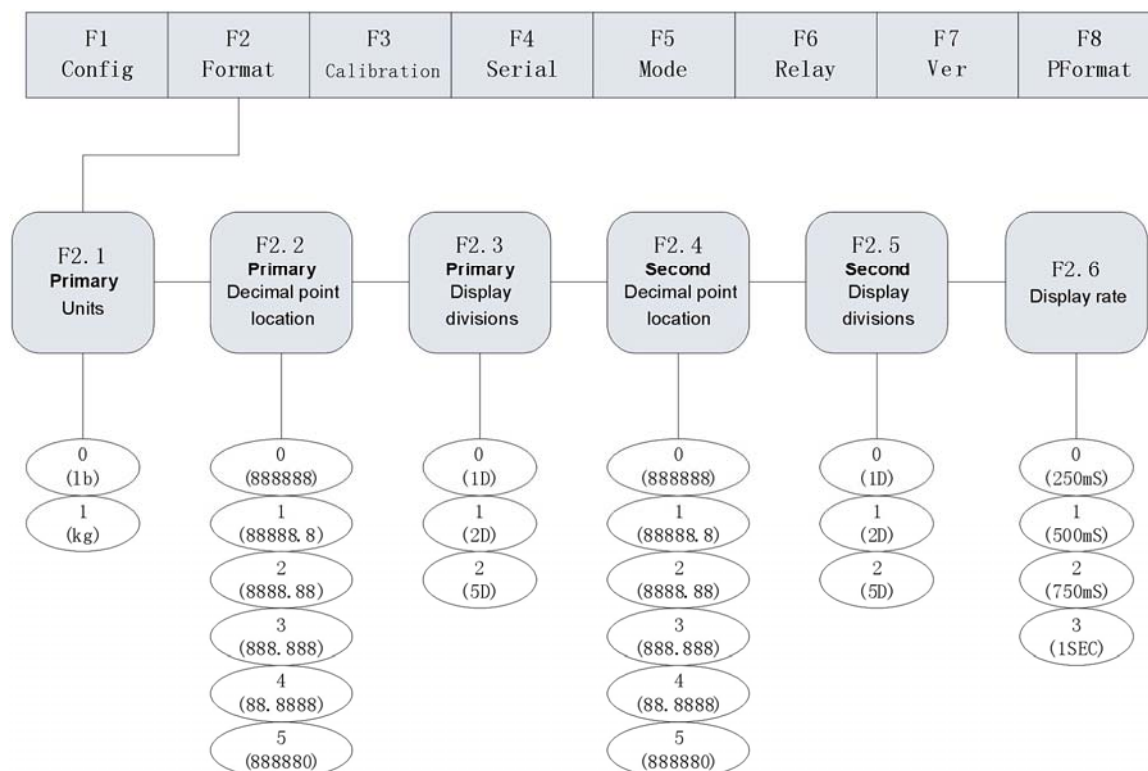

Fig. 3-5 F2 (Format) Menu

Table 3-2 F2(Format) Menu

F2 (Format) Menu		
Parameter	Choices	Description
Level 2 Submenu		
F2.1 (Primary Unit)	0 (lb)	Specifies the unit used of the Primary unit.
	1 (kg) ✓	
F2.2 (Primary Unit Decimal Point Location)	0 (888888)	Specifies the decimal position of the Primary unit. Note: If F2.4=5, when on calibration step F3.2 to edit the test weight value, you can only edit the number on the left-hand of the flashing cursor, e.g. if you want to edit the tens place, the cursor must be flashing on the ones place, and you couldn't edit the ones place.
	1 (88888.8) ✓	
	2 (8888.88)	
	3 (888.888)	
	4 (88.8888)	
F2.3 (Primary Unit Display Divisions)	0 (1) ✓	Specifies the display divisions of the Primary unit.
	1 (2)	
	2 (5)	

F2.4 (Assistant Unit Decimal Point location)	0 (888888) ✓	Specifies the decimal position of the Assistant unit. When F6.1 is set to 0 or 2, the decimal position of the Assistant unit is defined by the decimal position of the Primary unit. Only when F6.1 is set to 1 or 3, the decimal position of the Assistant unit could be set as F2.4 defined.
	1 (88888.8)	
	2 (8888.88)	
	3 (888.888)	
	4 (88.8888)	
F2.5 (Assistant Unit Display Divisions)	0 (1) ✓	Specifies the displayed divisions of the Assistant unit.
	1 (2)	
	2 (5)	
F2.6 (Display Rate)	0 (250ms) ✓	Sets the update rate for displayed values. Values are in milliseconds (ms) or seconds (s).
	1 (500ms)	
	2 (750ms)	
	3 (1s)	

**Note :** When selecting F6.1=0 (NTEP) or F6.1=2 (Canada), Assistant Unit Decimal Point Location and Assistant Unit Display Divisions will change automatically according to the Primary Unit Decimal Point Location and Primary Unit Display Divisions (refer to F6.1 Menu).

### 3.2.3 F3(Calibration) Menu

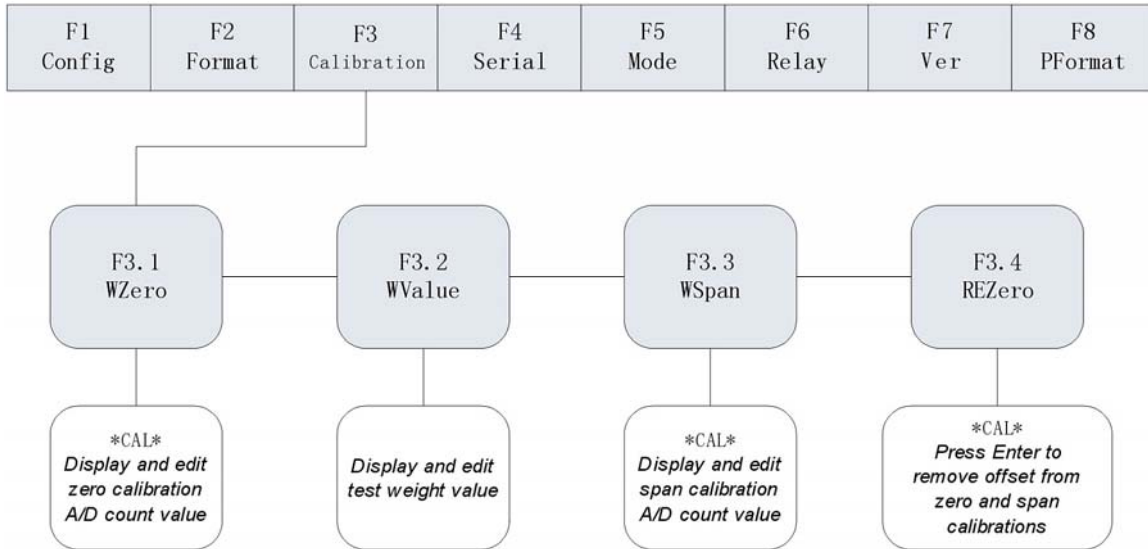

Fig. 3-6 F3 (Calibration) Menu

Table 3-3 F3(Calibration) Menu

F3 (Format) Menu
------------------

Parameter	Choices	Description
Level 2 Submenu		
F3.1 (WZero)	—	Display and edit the zero calibration A/D count value. Do not adjust this value after F3.3 (WValue) has been set. Refer to Section 4.
F3.2 (WValue)	—	Display and edit the test weight value, the value entered must above 100. Refer to Section 4.
F3.3 (WSpan)	—	Display and edit the span calibration A/D count value. If rezero isn't needed, press $\triangle$ to exit, leap over F3.4. Refer to Section 4.
F3.4 (REZero)	—	Press $\bigcirc$ to remove an offset value from the zero and span calibration. Use this parameter only after F3.1 (WZero) and F3.3 (WSpan) have been set. Refer to Section 4.

### 3.2.4 F4(Serial) Menu

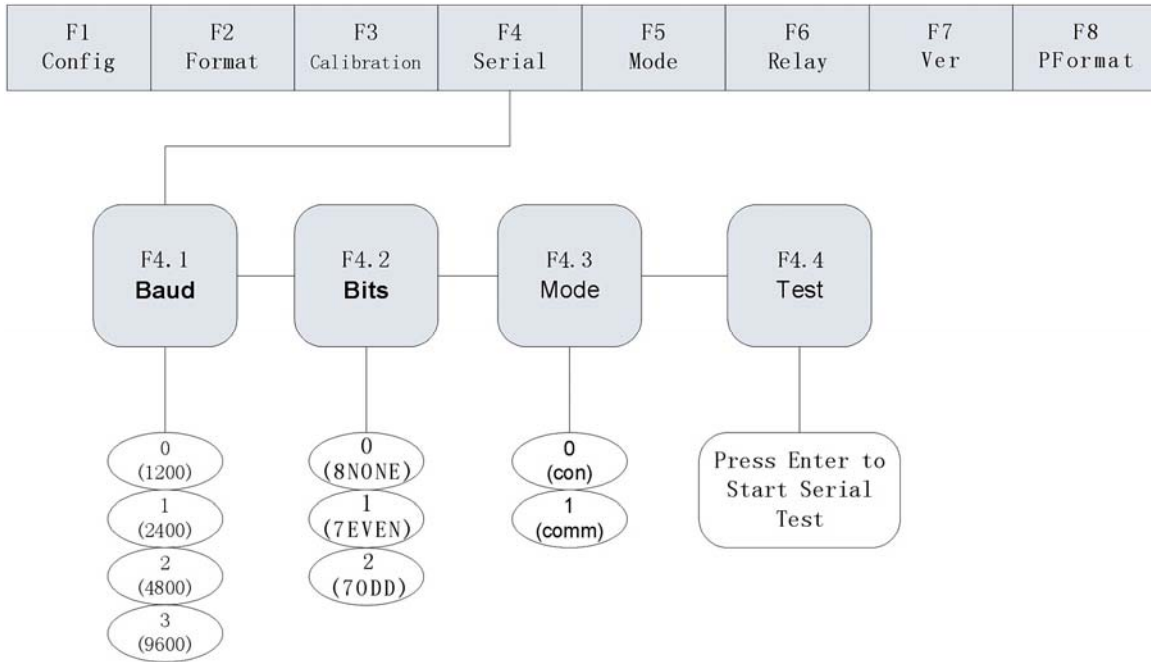



Fig. 3-7 F4(Serial) Menu

Table 3-4 F4 (Serial) Menu

F4 (Format) Menu		
Parameter	Choices	Description
Level 2 Submenu		

F4.1 (Baud)	0 (1200)	Specifies settings for baud rate.
	1 (2400)	
	2 (4800)	
	3 (9600) ✓	
F4.2 (Bits)	0 (8NONE) ✓	Specifies settings for the number of data bits.
	1 (7EVEN)	
	2 (7ODD)	
F4.3 (Mode)	0 (con)	Selects the mode of data transmission. 0(con) is for continuous transmission and 1(comm) is for transmission upon receiving commands. It must be set to 1 to use print function. Refer to Section 8.
	1 (comm) ✓	
F4.4 (Test)	—	Press  to perform serial communication tests between two indicators. Refer to Section 8.3

### 3.2.5 F5(Mode) Menu

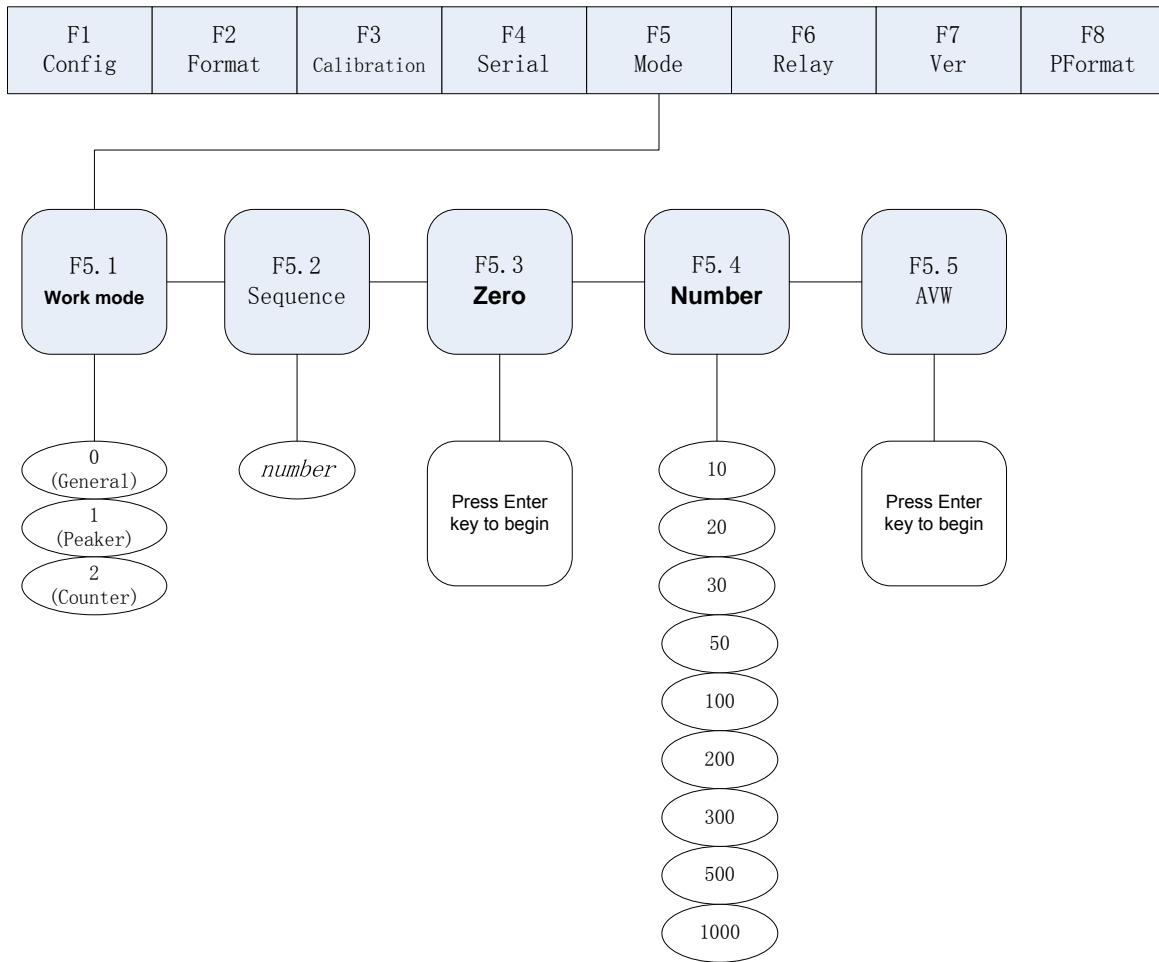

Fig. 3-8 F5(Mode) Menu

Table 3-5 F5(Mode) Menu

F5 (Mode) Menu		
Parameter	Choices	Description
Level 2 Submenu		
F5.1 (Work Mode)	0 (General) ✓	Selects one of the three operation modes. Refer to Section 1.5 for descriptions of three different operation modes. If you want to select Peaker and Counter Mode, F6.1 must be set to 3(NONE), otherwise, Peaker and Counter Mode won't be functional.
	1 (Peaker)	
	2 (Counter)	
F5.2 (Counted Item Code)	number	Specifies the item code number of counted items. Allowable numbers are 0 to 99. Refer to Section 5 for description of the setting of the counted item code.

F5.3 (Zero)	—	Sets the scale to zero before inputting the average weight of counted items. Refer to Section 5.
F5.4 (Sampling Quantity)	10	Specifies the quantity of sample counted items. Refer to Section 5.
	20	
	30	
	50	
	100	
	200	
	300	
	500	
F5.5 (Average Weight)	—	Displays and edits the average weight of the counted items. Refer to Section 5.

### 3.2.6 F6(Relay) Menu

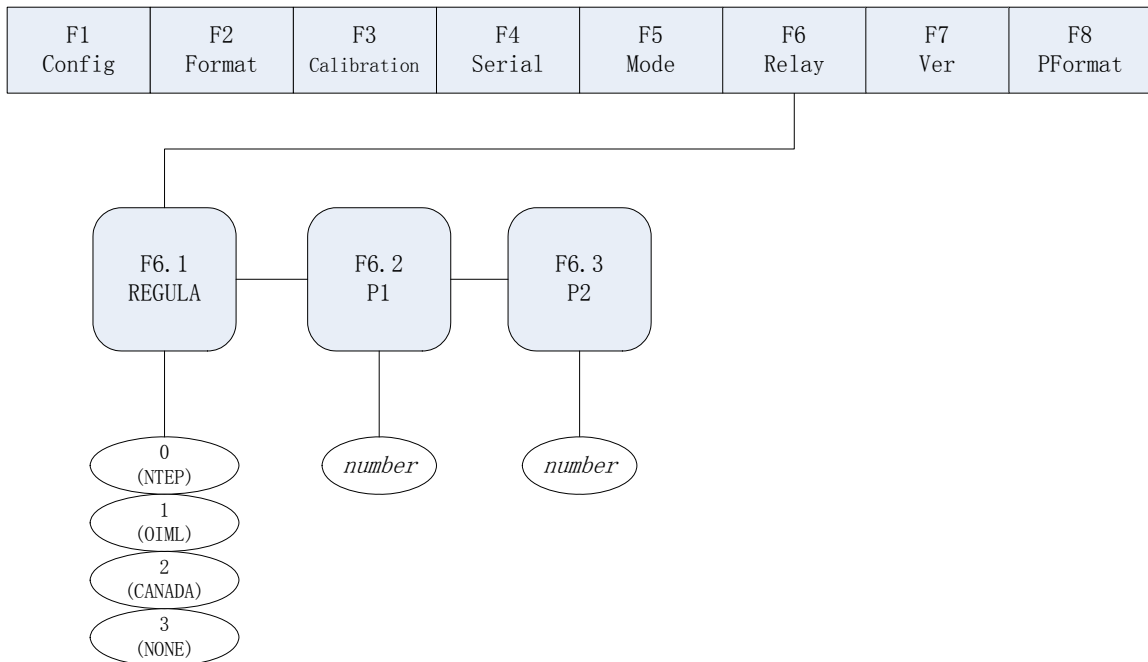

Fig. 3-9 F6(Relay) Menu

Table 3-6 F6(Relay) Menu

F6 (Relay) Menu		
Parameter	Choices	Description
Level 2 Submenu		
	0 (NTEP)	For OIML, NTEP and CANADA application, Tare

F6.1 (mode)	1 (OMIL)	removal is only allowed when Gross = 0. When NONE is selected, Tare removal can be done at any weighing mode. For NTEP and OIML, a new Tare can be acquired even when there is a stored Tare. For CANADA, a new Tare can be acquired after the stored Tare is removed. For NONE, NTEP and CANADA, when the current weight is within the specified zero range, zero scale can be performed irrespective it is in Gross or Net mode. For OIML, zero scale can only be performed when it is in Gross mode and Tare can be removed when it is in Net mode.
	2 (CANADA)	
	3 (NONE)	
F6.2 (P1)	Number	Specifies fixed value 1. Refer to Section 6 for Relay Output setup.
F6.3 (P2)	Number	Specifies fixed value 2. Refer to Section 6 for Relay Output setup

### 3.2.7 F7(Ver) Menu

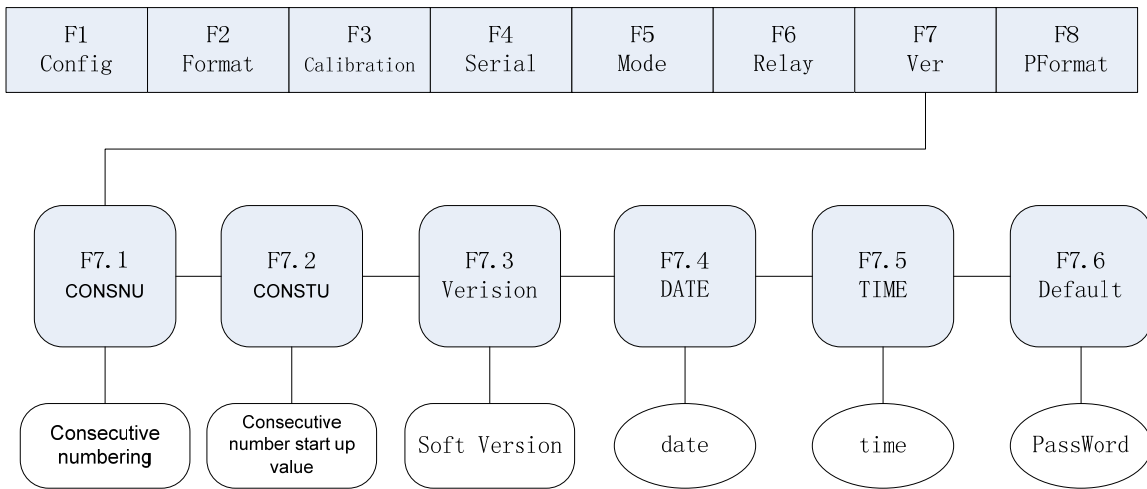

Fig. 3-10 F7(Ver) Menu

Table 3-7 F7(Ver) Menu

F7 (Ver) Menu		
Parameter	Choices	Description
Level 2 Submenu		

F7.1 (CONSNU)	Number	Consecutive Numbering. Allows sequential numbering for print operations. The consecutive number value is incremented following each print operation. The initial value of this parameter is set to the start up value specified on the CONSTU (F7.2 value). Refer to Section 7.4
F7.2 (CONSTU)	Number	Consecutive Number Start Up Value. Refer to Section 7.4
F7.3 (Version)	Soft Version	Displays the software version installed in the indicator. This value cannot be altered.
F7.4 (DATE)	Date	Setting of date as "DD.MM.YY"
F7.5 (TIME)	Time	Setting of time as "HH.MM.SS"
F7.6 (Default)	Number	Press <input type="radio"/> after inputting the PassWord to recover the default value in the ROM. Refer to Appendix 9-2.



### 3.2.8 F8(PFormat) Menu

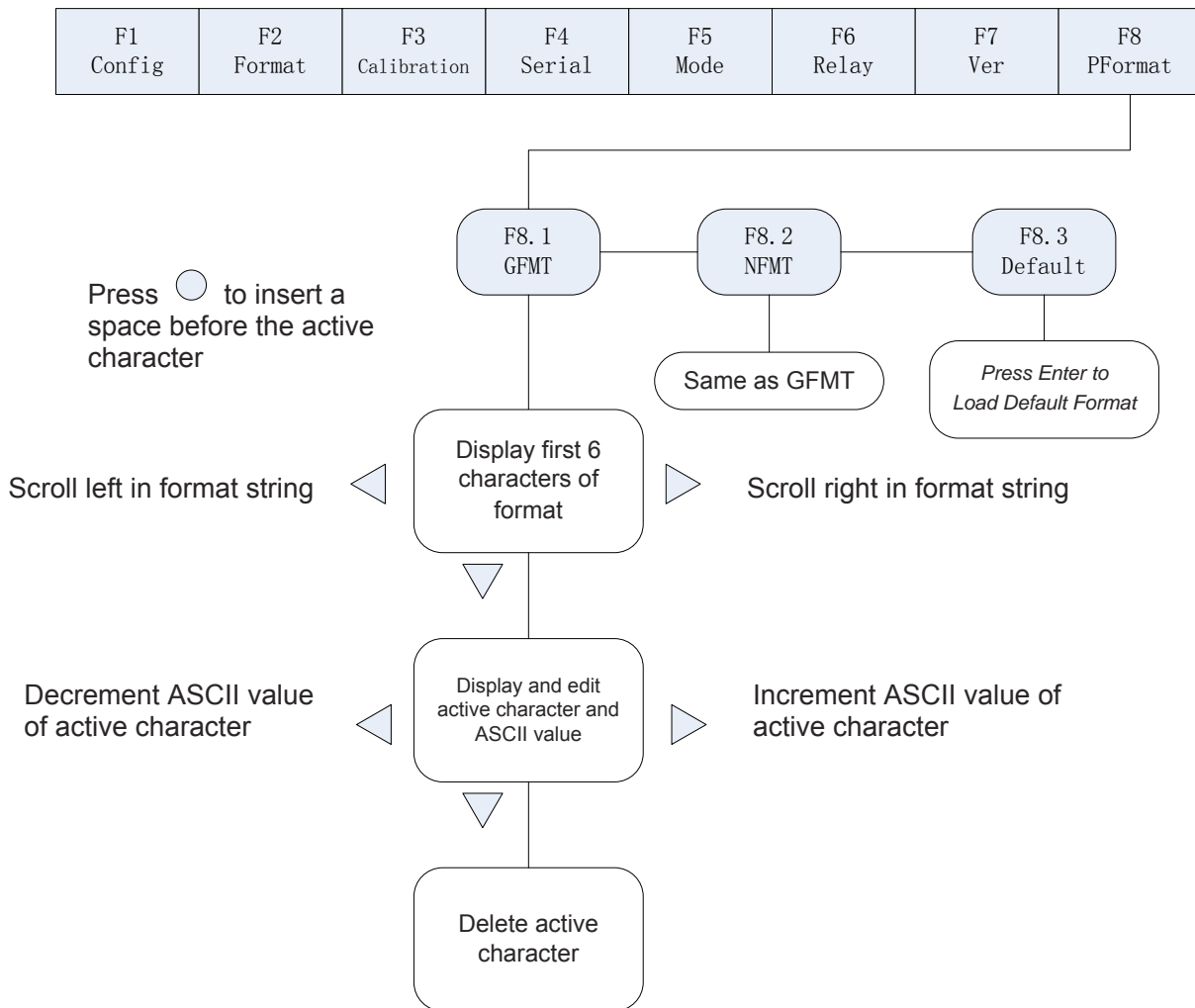

Fig. 3-11 F8(PFormat) Menu

F8 (PFormat) Menu is used for setting Print format of serial print output. Refer to Section 7.

## 4. Calibration

The calibration of 805TS consists of the following steps:

- Zero calibration
- Entering the test weight value
- Span calibration
- Optional re-zero calibration for test weights using hooks or chains.

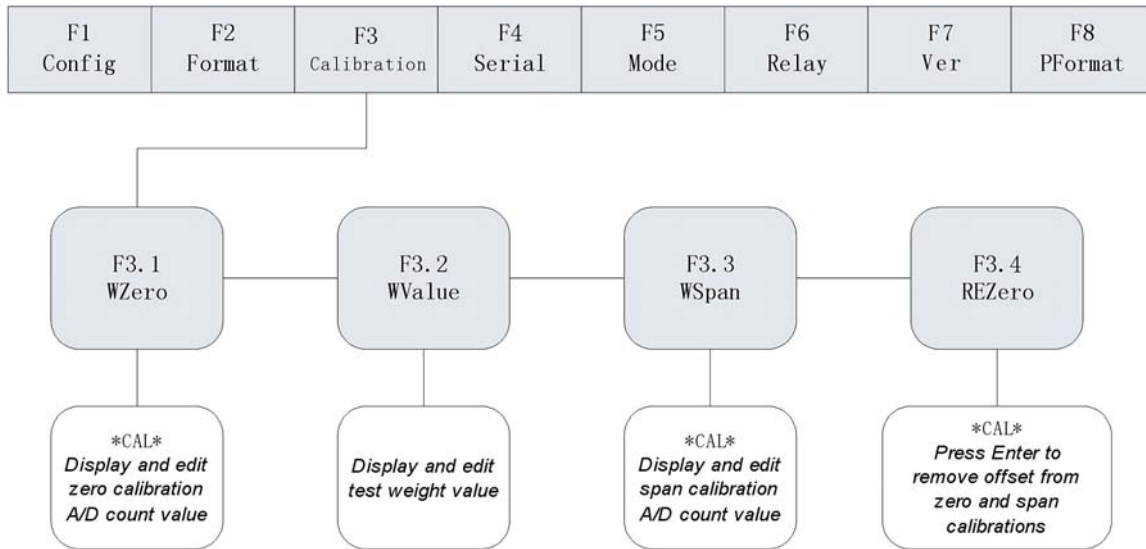

Fig. 4-1 F3(Calibration) Menu

The following section describes calibration procedure for each of the calibration methods:

- (1) Turn on the K1 switch to set indicator to the Configuration mode (display shows “F 1”) and remove all weight from the scale platform. If the test weights require hooks or chains, place the hooks or chains on the scale for zero calibration.
- (2) Press  $\blacktriangleright$  until the display shows “F 3” (see Fig. 4-1). Press  $\blacktriangledown$  to go to zero calibration mode. Display shows “F 3” (see Fig. 4-1).
- (3) When display shows “F 3.1”, there are 2 options :
  - Press  $\bigcirc$  to zero calibration. Display shows “CAL” while calibration is in progress. When complete, the A/D count for the zero calibration is displayed. Do not adjust this value. Press  $\bigcirc$  again to save the zero calibration value and go to the next menu (display shows “F 3.2”).
  - Press  $\blacktriangledown$ , display shows the A/D count of the original zero calibration. It can be edited following Fig. 4-2. When complete, press  $\bigcirc$  to save and to go to the next menu. Display shows “F 3.2”.
- (4) When display shows “F 3.2”, place test weight on the scale and press  $\blacktriangledown$  to show the test weight value. Follow Fig. 4-2 to input the test weight value, then press  $\bigcirc$  to save the value and go to the next menu. Display shows “F 3.3”.
- (5) When display shows “F 3.3”, there are 2 options :
  - Press  $\bigcirc$  to calibrate span. Display shows “CAL” while calibration is in progress. When complete, the A/D count for the span calibration is shown. Do not adjust this value. Press  $\bigcirc$  again to save the span calibration value and go to the next menu. Display shows “F 3.4”.
  - Press  $\blacktriangledown$  to show the A/D count of the original span calibration. It can be edited following Fig. 4-2. When complete, press  $\bigcirc$  to return to F3.4 Menu. Display shows “F3.4”.

- (6) F 3.4 Menu is used to remove a calibration offset when hooks or chains are used to hang the test weights.

When display shows “F3.4”, there are 2 options :

- If no other apparatus is used to hang the test weights during calibration, remove the test weight and press  $\triangle$  to return to F4 Menu. Display shows “F4”
  - If hooks or chains are used during calibration, remove these and the test weights from the scale. With all weight removed, press  $\bigcirc$  to re-zero the scale. This function adjusts the zero and span calibration values. Display shows “CAL” while zero and span calibrations are adjusted. When complete, the adjusted A/D count for the zero calibration is shown. Press  $\bigcirc$  to save the value and to return to F4 Menu. Display shows “F4”.
- (7) Turn off the K1 switch to exit from Calibration mode and enter into Weighing Mode.

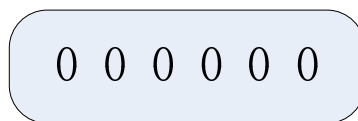

Fig. 4-2 Editing Procedure for Numerical Values

When editing numerical values, press  $\blacktriangleright$ ,  $\blacktriangleleft$  to change the digit selected. Press  $\triangle$ ,  $\nabla$  to increase or decrease the value of the selected digit.

**Suggestion:** *When finish calibrating (including F3.4 Menu operations), record the values of F3.1, F3.2 and F3.3. When certain parameters were accidentally altered, the data can be recovered by following the procedure in the above points (3), (4) and (5). It is no need to re-calibrate all over again.*

## 5. Count Items Average Weight Setup

When Count mode is selected in F5.1 Menu, it is required to set up the average weight of the count items. The indicator can be set up for up to 100 count items. The set up consists of the following steps:

- Item code
- Zero scale
- Sample quantity
- Confirming Count Items Average Weight

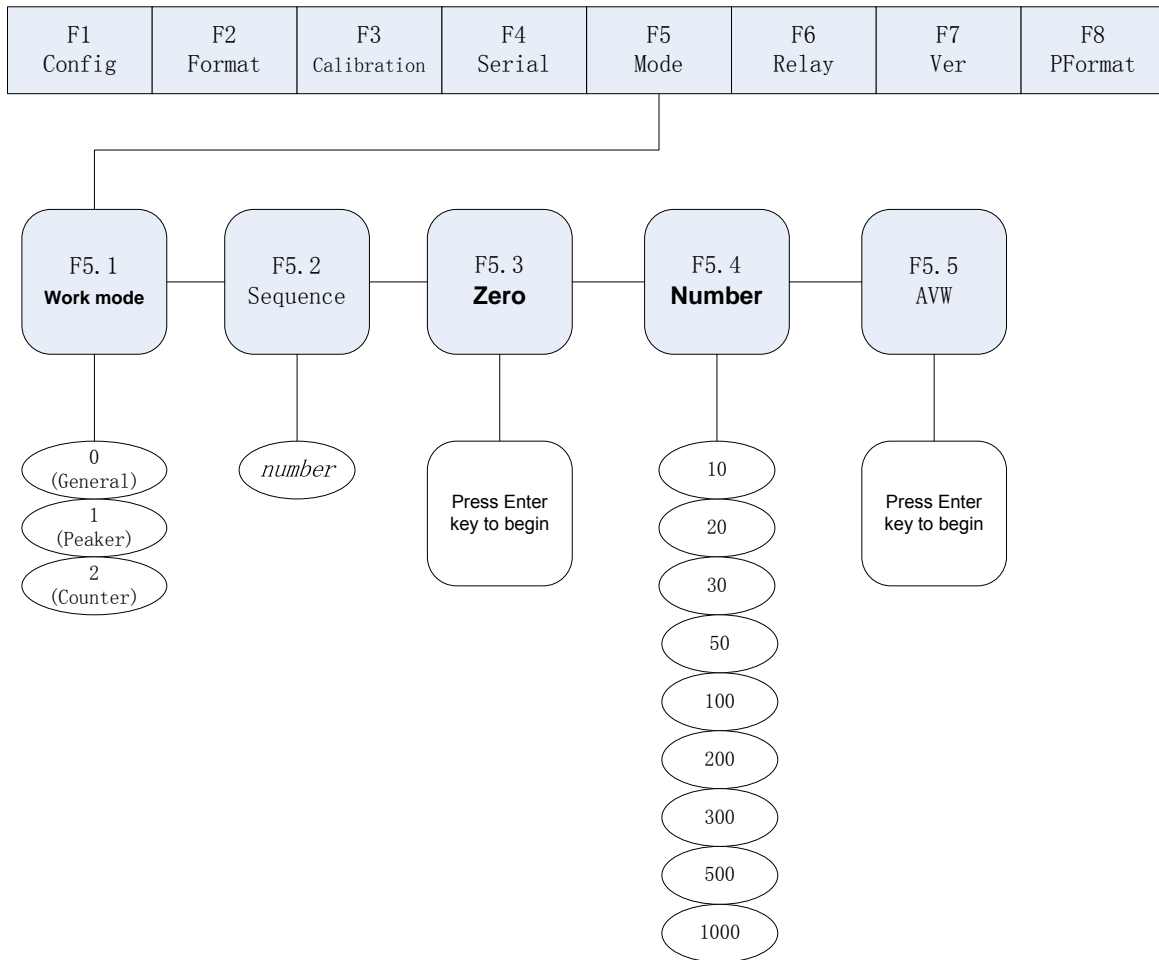











Fig. 5-1 Count Items Average Weight Setup Menu

Setup procedure is as follow:







- (1) Turn on the K1 switch to set indicator to the Configuration mode (display shows “F1”).
- (2) Press  $\blacktriangleright$  until display shows “F5.1” (see Fig 5-1). Press  $\blacktriangledown$  to go to Count Items Average Weight setup menu and display shows “F5.1”. Press  $\blacktriangleright$  to show “F5.2”.
- (3) Press  $\bigcirc$  when display shows “F5.2”. Display shows the code number of the required count items. Following the procedure in Fig. 4-2 to input and edit the code. The allowable selected numbers are 0 to 99. Press  $\bigcirc$  to save the code number and to go to the next menu. The display shows “F5.3”.
- (4) Remove all the weight from the scale platform when display shows “F5.3”. Press  $\bigcirc$  to zero the scale. Display shows “CAL” while processing the zeroing operation. When complete, display shows “F5.4”.
- (5) Press  $\blacktriangledown$  when display shows “F5.4”. Display shows the sampling quantity of the count items. Use  $\blacktriangleleft$ ,  $\blacktriangleright$  keys to specify the sampling quantity. Place the same quantity of the sample count items onto the scale platform as the input sampling

- quantity. Press  to go to the next menu. Display shows “F5.5”.
- (6) Press  when display shows “F5.5”. Display shows “CAL” while processing the average weight setting. When complete, there are 2 possible outcomes :
- The average weight is too small and display shows “—E5—”. Press  to return to F5.5 Menu and display shows “F5.5”. There are two options :
    - Combine a few small items as one sample. Place the same sampling quantity as specified in F5.4 Menu. Press  to perform the average weight calculation.
    - Press  to cancel average weight setting and return to F5 Menu. Display shows “F5”.
  - The average weight is normal and display shows the quantity of the count item “nxxxxx”. Press ,  to edit count item quantity and weight. Press  to return to F5.2 Menu and display shows “F5.2”
- (7) There are 2 options when display shows “F5.2”.
- Repeat (3) to (6) if another average weight setting is required.
  - Press  to return to F5 Menu if no more average weight setting is required. Display shows “F5”.
- (8) Turn off the K1 switch to exit from Calibration mode and enter into Weighing Mode.

## 6. Relay Output Setup

There are two signal outputs, one lower and one upper, in the Relay function. When the weight value (see Note 2) is smaller than the setting in F6.2, Relay 1 is on. When it is greater than the setting in F6.2, Relay 1 is off. When the weight value is smaller than the setting in F6.3, Relay 2 is off. When it is greater than the setting in F6.3, Relay 2 is on. See Fig. 6-2.

Setup procedure :

- (1) Turn on the K1 switch to set indicator to the Configuration mode (display shows “F1”).
- (2) Press  until display shows “F6” (see Fig. 6-1). Press  to go to the Relay Output Menu. Display shows “F6.1”
- (3) When displays shows “F6.1”, press  to go to the F6.2 Menu and display shows “F6.2”.
- (4) When display shows “F6.2”, press  and display shows the value of Relay 1 setting. Edit Relay value according to editing procedures in Fig. 4-2. When complete, press  to store the value and return to F6.3 Menu. Display shows “F6.3”.
- (5) When display shows “F6.3”, press  and display shows the value of Relay 2 setting. Edit Relay value according to Fig. 4-2. When complete, press  to store the value and return to F6.1 Menu. Display shows “F6.1”.

(6) Turn off the K1 switch to exit from Calibration mode and enter into Weighing Mode.

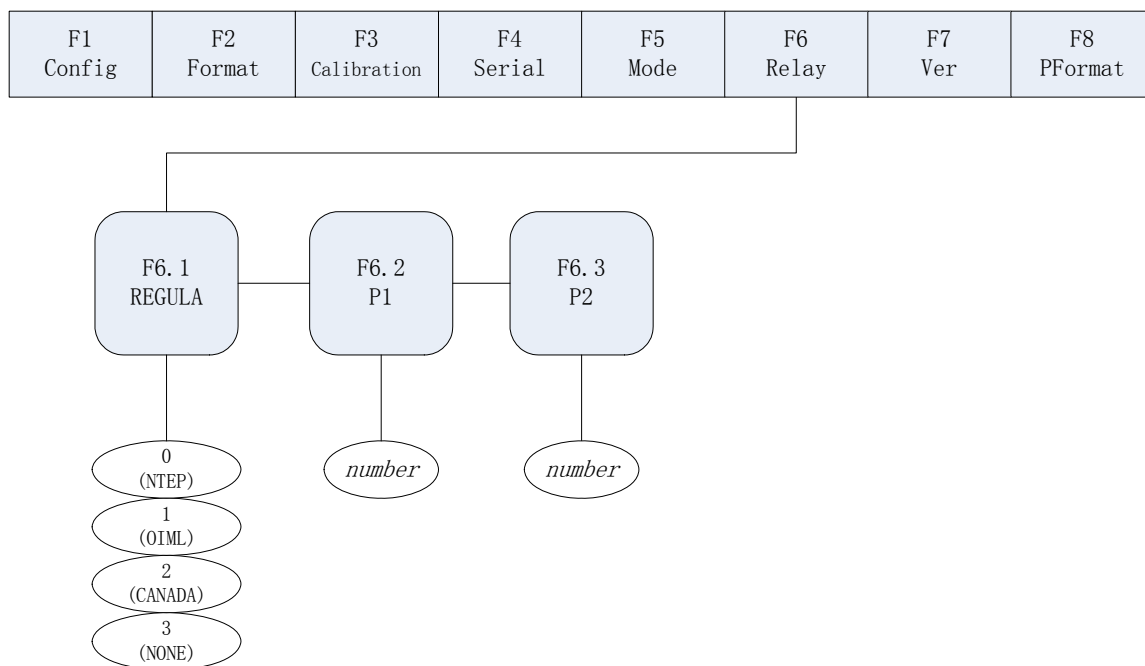

Fig. 6-1 Relay Output Menu

Fig. 6-2 Relay Output-Upper and Lower Values

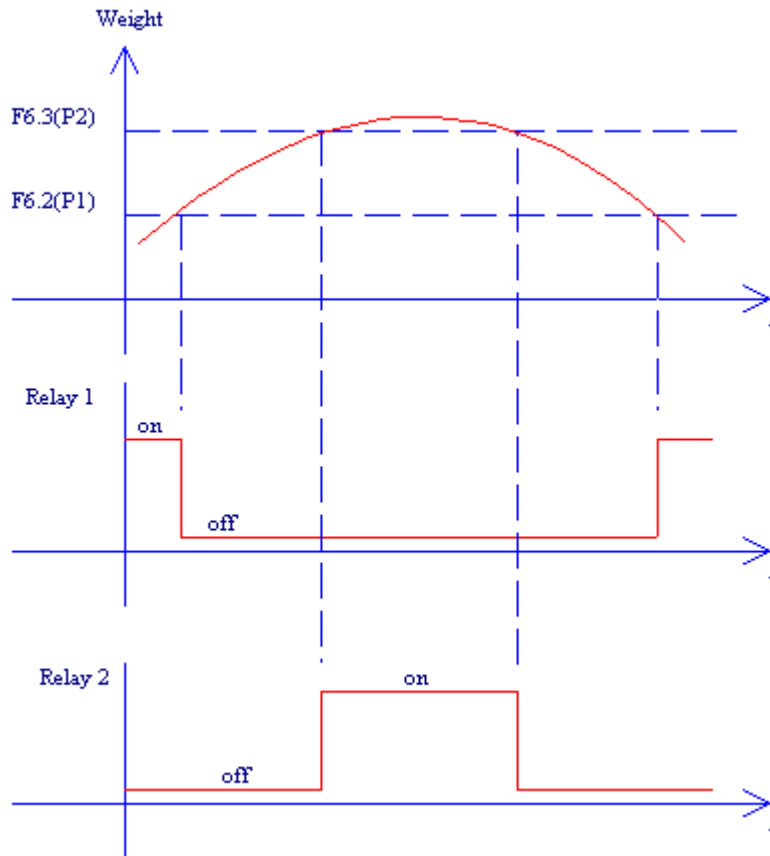

Fig. 6-2 Relay Output-Upper and Lower Values

**Note 1 : Must ensure F6.3 (P2) value > F6.2(P1) value to give proper relay output**

**Note 2: weight value is in net weight and is according to the unit in F2.1 setting (Refer to F2 Menu in Section 3.2.2).**

## 7. Print Format

2 print formats via the serial port output

- Gross weight print format
- Net weight print format

After confirming print format GFMT and NMFT, press **【PRINT】** for printing operation.

When the gross weight stored is something other than 0, use NFMT format. In other cases, use GFMT format.

### 7.1 Print Format Commands

Print format commands are as shown in Table 7-1. Command included in the format strings must be enclosed between < > delimiters. Any characters outside of the delimiters are

printed as text on the ticket. Text characters can include any ASCII character shown in Appendix 9-4. The maximum number of characters that can be input into each print format is 250.

Table 7-1 Print Format Commands

Command	Description
<G>	Gross weight in displayed units. The format is "XXXXXXX UU" where "XXXXXXX" is the weight and "UU" is the unit
<N>	Net weight in displayed units. Same format as in <G> command
<T>	Tare weight in displayed units. Same format as in <G> command.
<CN>	Consecutive number. The Format is "XXXXXX". See Section 7-1. For print consecutive number setting.
<CD>	Count item code (used only when Count Mode is set). The format is "XX". See Section 1.5.3.6 for count item code setting.
<CO>	Count item quantity (used only when Count Mode is set). The format is "XXXXX".
<D>	Date of printing. Format : dd-mm-yy, where dd is the day, mm is the month and yy is the year.
<I>	Time of printing. Format : HH:MM:SS, where HH is the hour, MM is the minute and SS is the second.
<P>	Peak mode value (used only when Peak Mode is set). The format is "XXXXXXX" (including decimal point)
<NLnn>	New line (nn is the number for CR and LF. Value must be in the range 1-99. If nn is not specified, 1 is assumed).
<SPnn>	Space (nn=number of space. Value must be in the range 1-99. If nn is not specified, 1 is assumed).
<E>	Command to complete print format setting. If a command is not ended with the <E> command, indicator is operated without print mode

When indicator is set to Default Format String, use Table 7-2 for the default print format.

Table 7-2 Default Print Format

Format	Default Format String	Sample Output
GFMT	<G>GROSS<NL>	1564.23 LB GROSS
NFMT	<G>GROSS<NL> <T>TARE<NL> <N>NET<NL>	4567.2 LB GROSS 23.5 LB TARE 4543.7 LB NET

## 7.2 GFMT and NFMT Print Format Input

Setting of GFMT and NFMT is as follow:



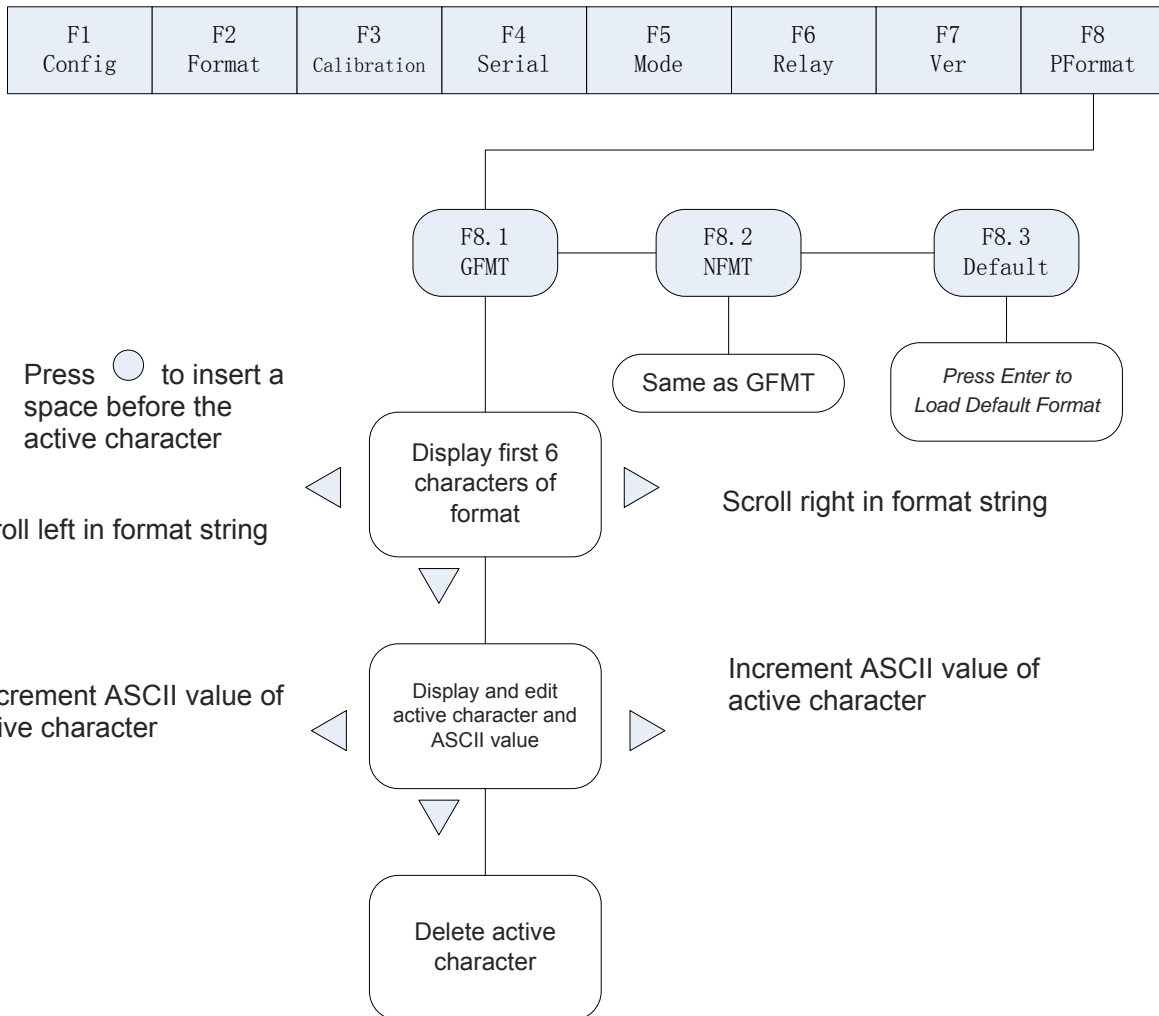

Fig. 7-1 Print Format Input Flow Diagram

- (1) Turn on the K1 switch to set indicator to the Configuration mode (display shows “F 1”)
- (2) Press to show “F 8” (see Fig. 7-1). Press to Print Format Menu and display shows “F 8.1”.
- (3) When display shows “F 8.1”, press again and display shows the first 6 digits of GFMT format.
- (4) Use , to move the cursor to different flashing digits. When it is at the far right position, press again, the first digit at the left is removed and another digit prompts up at the right. When it is at the far left position, press , the last digit at the right is removed and another digit prompts up at the left. Press to add a space to the left of the flashing digit.
- (5) When the cursor at a certain digit position, press to edit. Display shows the characters as shown in Appendix 9-5. “-” is shown for characters not available in Appendix 9-5.

- (6) When complete character editing, press  $\triangle$  to return to (4) above and to perform editing other characters. When finish editing, press  $\triangle$  to return to F8.1 and display shows "F8.1".
- (7) Press  $\blacktriangleright$  to go to F8.2 Menu and display shows "F8.2". Refer to (3) to (6) for format editing of NFMT.
- (8) After finishing, turn off the K1 switch to exit from Calibration mode and enter into Weighing Mode.

**Note:** When inputting characters, display shows characters as per Table 7-2. "--" is shown for unavailable characters.

### 7.3 Default Formatting

- (1) Turn on the K1 switch to set indicator to the Configuration mode and display shows "F1".
- (2) Press  $\blacktriangleright$  until display shows "F8" (see Fig. 7-1). Press  $\blacktriangledown$  to go to Print output menu and display shows "F8.1".
- (3) When display shows "F8.1", press  $\blacktriangleright$  twice and display shows "F8.3".
- (4) When display shows "F8.3", press  $\bigcirc$  to show "Set?". There are 2 options then:
  - Press  $\bigcirc$  to change GFMT and NFMT format characters to default value in Table 7-2, and then return to F8 Menu. Display shows "F8".
  - Press  $\triangle$  to give up restored default format operation and to return to F8 Menu. Display shows "F8".
- (5) Turn off the K1 switch to exit from Calibration mode and enter into Weighing Mode.

### 7.4 Print Consecutive Number

Set print consecutive number in Print mode. F7.1 Menu (CONSNU) is the current consecutive number. The consecutive number value is increased by 1 following each print operation. When start up indicator, F7.2 is assigned as the initial consecutive number. F7.2 is used to set the initial consecutive number. Refer to F7.1 Menu and F7.2 Menu for details.

## Detailed Setup Procedure:

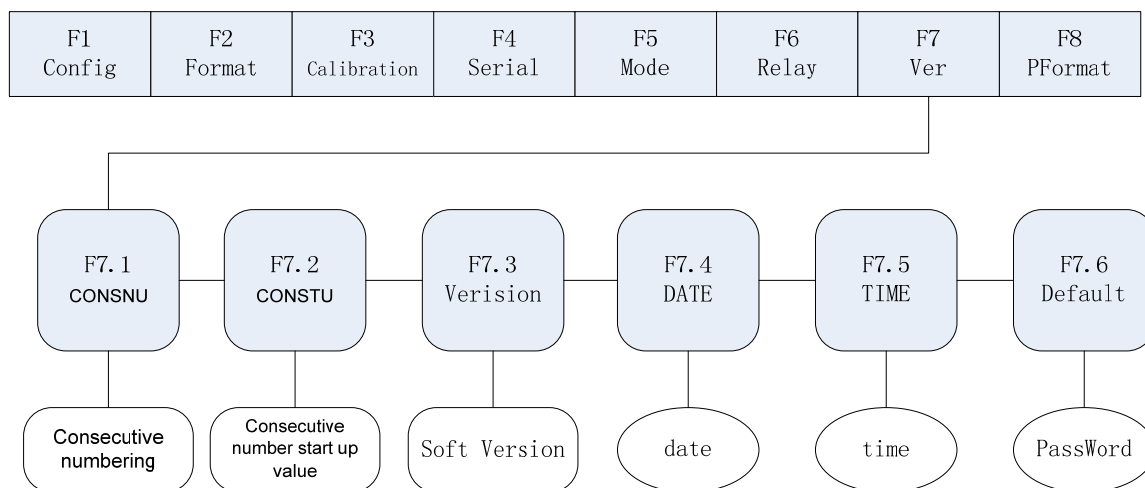

Fig. 7-2 Consecutive Numbering Setup

- (1) Turn on the K1 switch to set indicator to the Configuration mode. Display shows "F1".
- (2) Press  $\blacktriangleright$  until display shows "F7" (see Fig. 7-2). Press  $\blacktriangledown$  to go to F7.1 Menu. Display shows "F7.1"
- (3) When display shows "F 7.1", press  $\blacktriangledown$ . Display shows the current consecutive number "nnnnnn". Edit numbers according to Fig. 4-2.
- (4) After editing, press  $\bigcirc$  to return to F7.2 Menu. Display shows "F7.2"
- (5) When display shows "F7.2", press  $\blacktriangledown$ . Display shows "nnnnnn". Edit numbers according to Fig. 4-2.
- (6) After editing, press  $\bigcirc$  to return to F7.3 Menu. Display shows "F7.3".
- (7) Turn off the K1 switch to exit from Calibration mode and enter into Weighing Mode.

## 7.5 Date and Time Setting

- (1) Follow points (1) and (2) to enter into F7 Menu.
- (2) When display shows "F7.1", press  $\blacktriangleright$  until display shows "F7.4" (see Fig. 7-2). Press  $\blacktriangledown$  to enter into Date setup mode and display shows "DD.MM.YY". Follow Fig. 4-2 to set to the current date.
- (3) When date setup is complete, press  $\bigcirc$  to return to F7.5 Menu. Display shows "F7.5".
- (4) When display shows "F7.5", press  $\blacktriangledown$  and display shows time "HH.MM.SS". Follow Fig. 4-2 to set the current time.
- (5) When complete, press  $\bigcirc$  to return to F7.6 Menu. Display shows "F7.6".

(6) Turn off the K1 switch to exit from Calibration mode and enter into Weighing Mode.

## 8. Serial Communication

Indicator has the following two serial communication modes:

- Continuous transmission
- Transmission upon request (from an external PC)

Set up Baud, Bits, Parity, Mode and Test in F4 Menu.

Detailed Setup Procedure is as follow:

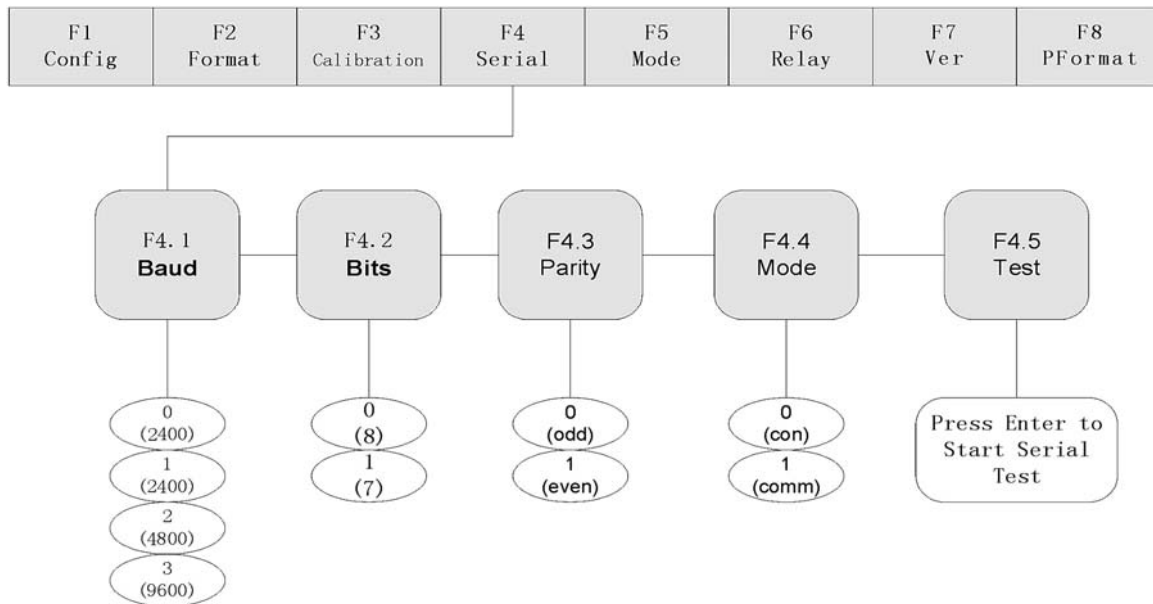

Fig. 8-1 Serial Communication Menu

### 8.1 Continuous Transmission

- (1) Turn on the K1 switch to set indicator to the Configuration mode. Display shows "F1"
- (2) Press  $\blacktriangleright$  until display shows "F4" (see Fig. 8-1). Press  $\blacktriangledown$  to go to F4 Menu. Display shows "F4.1".
- (3) When display shows "F4.1", press  $\blacktriangleright$  until display shows "F4.4".
- (4) When display shows "F4.4", press  $\blacktriangledown$  to show serial communication code. Use  $\blacktriangleright$  to set serial communication code to 0 (data transmitted continuously).
- (5) Turn off the K1 switch to exit from Calibration mode and enter into Weighing Mode. After selecting continuous transmission mode (F4.4=0), indicator transmits data continuously according to Fig. 8-2.

**Note: Other items in F4 Menu are for Baud, Bits Test and etc. Start and stop are set**

at 1. These parameters are suitable for continuous transmission and transmission upon request modes.

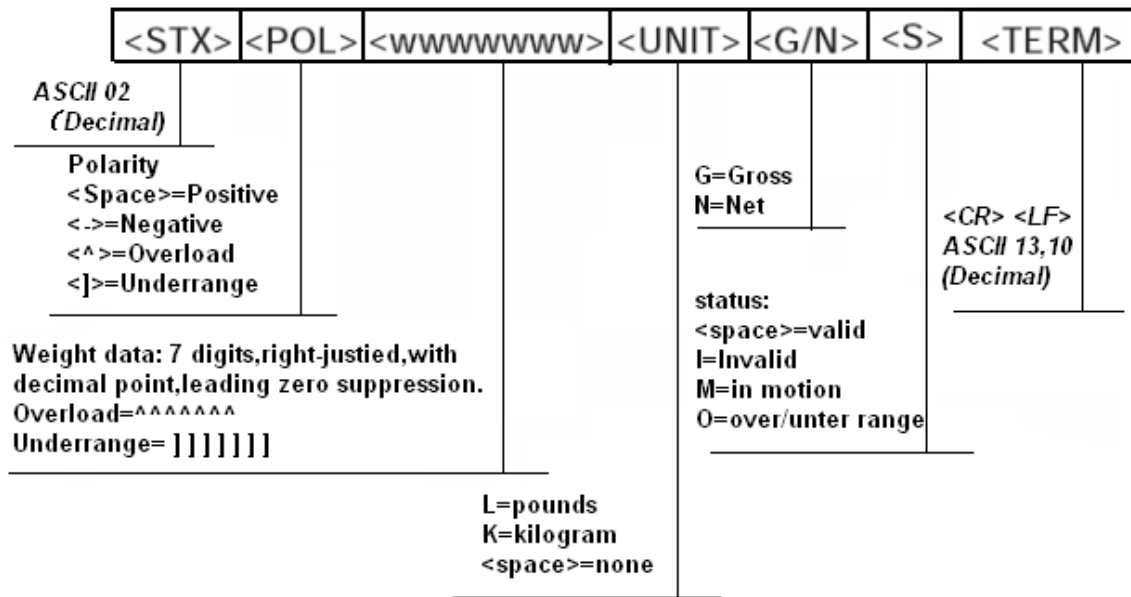

Fig. 8-2 Format of Continuous Transmission

## 8.2 Transmission Upon Request

Specify F4.4=1 as Section 8.1 above. After selecting the mode, indicator transmits data upon request according to Fig. 8-3 and Fig. 8-4.

When receiving a command, indicator sends "OK" after transmitting the requested data. Indicator sends "??" if it receives undefined or incorrect request or command.

### 8.2.1 Data Transmission Sequence

- Transmission Format from PC

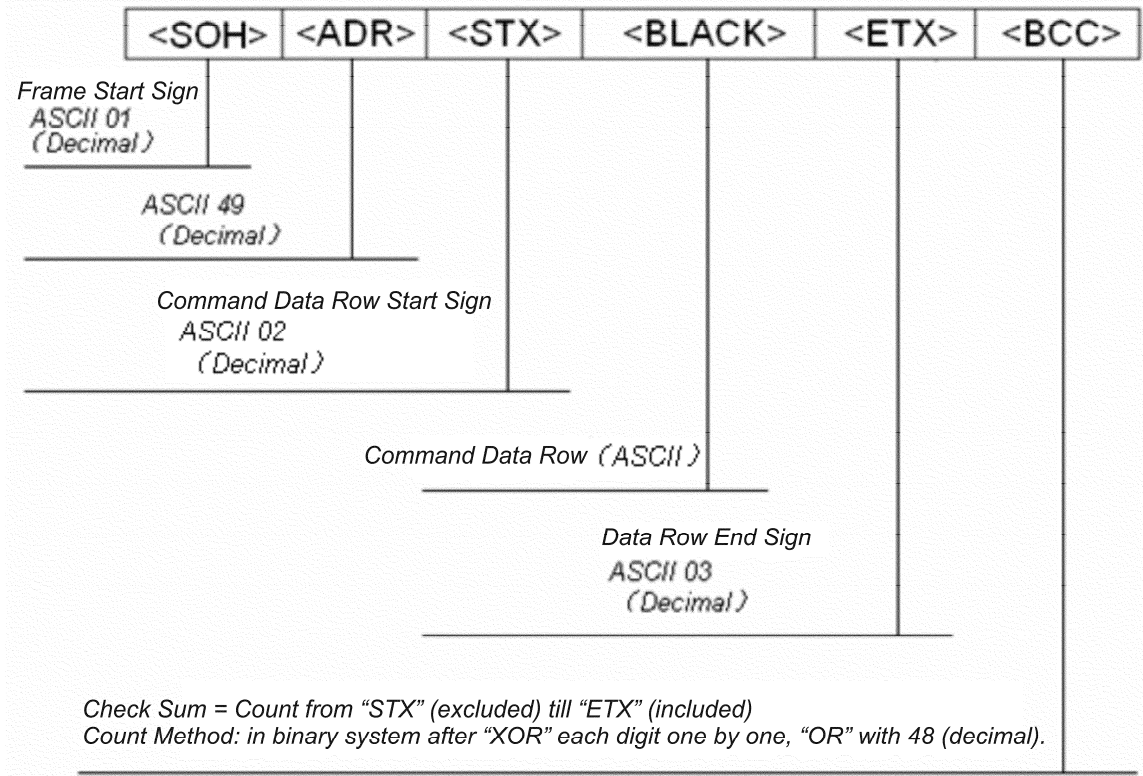

Fig. 8-3 Transmission Format from PC

Example : Set BLOCK to "G" (which is 47H) in ASCII code. Inspection and BCC calculation are as follow:

ASCII	HEX	BCC	
G	47H	47H	
ETX	03H	44H	
	30H	74H	"OR" with 30H

- Respond Format from Indicator

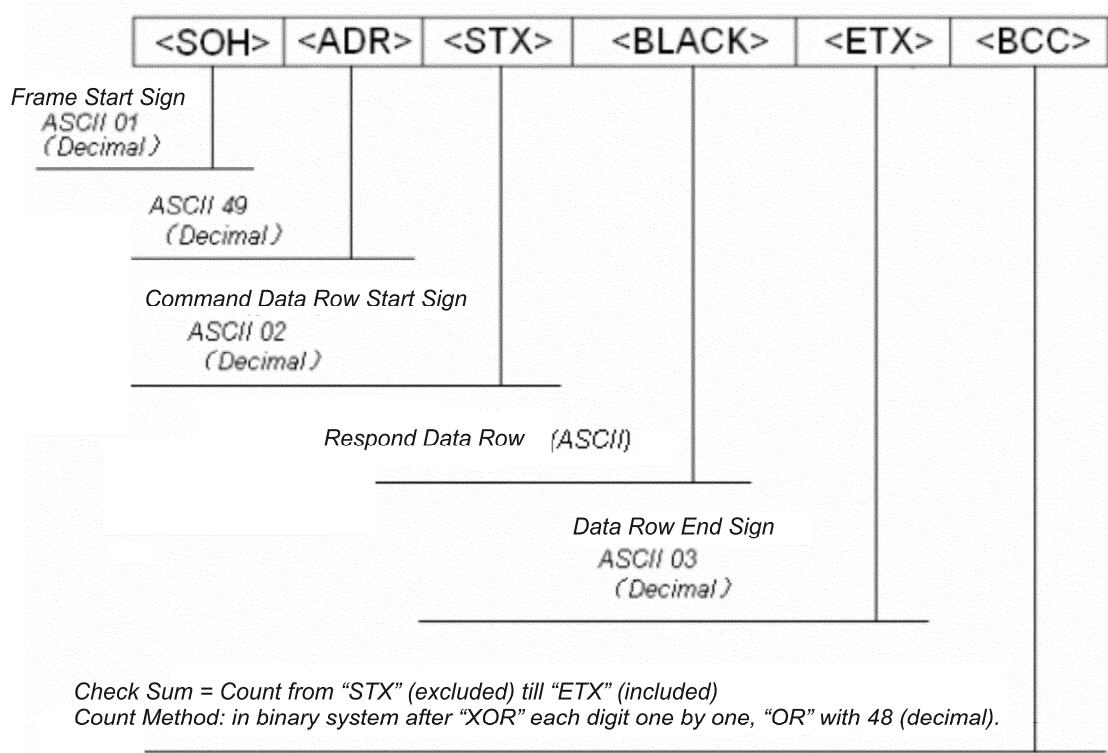

Fig. 8-4 Respond Format from Indicator

## 8.2.2 Communication Command

### 8.2.2.1 Transmit Current Weight Value

Command data from PC<BLACK> Format: G (ASCII 71)

Response data from indicator<BLACK> Format see Fig. 8-5

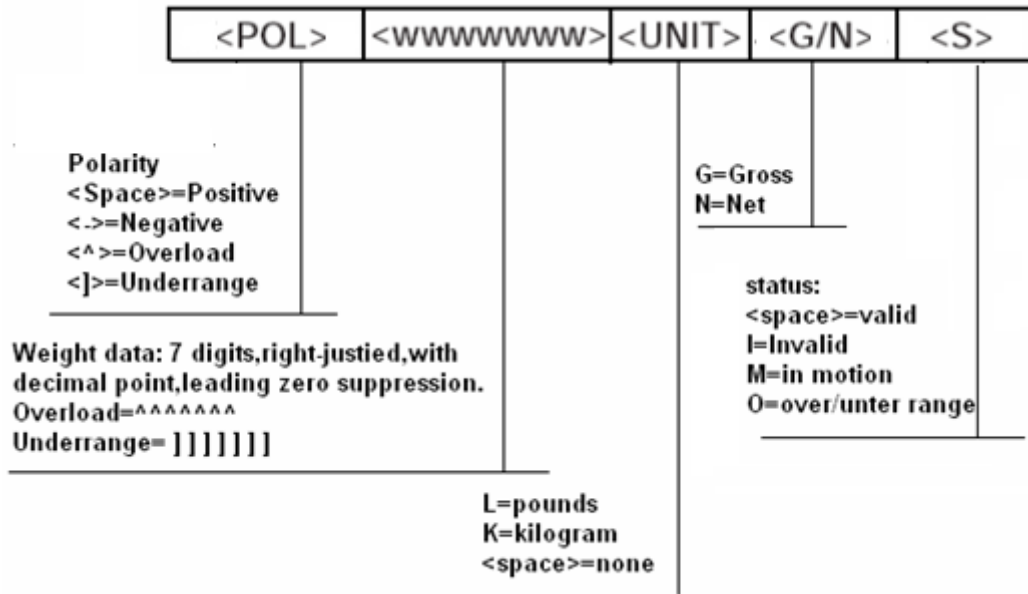

Fig. 8-5 Respond to<BLACK>data after receiving G command

Example: PC receives data from indicator

PC sends: 01H, 31H, 02H, **47H**, 03H, 74H

Indicator responds: 01H, 31H, 02H, **20H, 20H, 20H, 20H, 31H, 30H, 37H, 32H, 4BH, 47H, 20H**, 03H, 3BH

Data received in gross weight 1072kg.

### 8.2.2.2 Zero Scale

PC command data <BLACK> format : Z (ASCII 90)

Indicator receives correctly and responds data <BLACK> =“OK”

Example : PC sends command to indicator to zero scale

PC sends: 01H, 31H, 02H, **5AH**, 03H, 79H

Indicator responds: 01H, 31H, 02H, **4FH, 4BH**, 03H, 37H

### 8.2.2.3 Print Format Transmission Command

The format of PC sending command to indicator is different from other commands sent by the PC. Details are as follow:

Format of PC command is as Fig. 8-6:



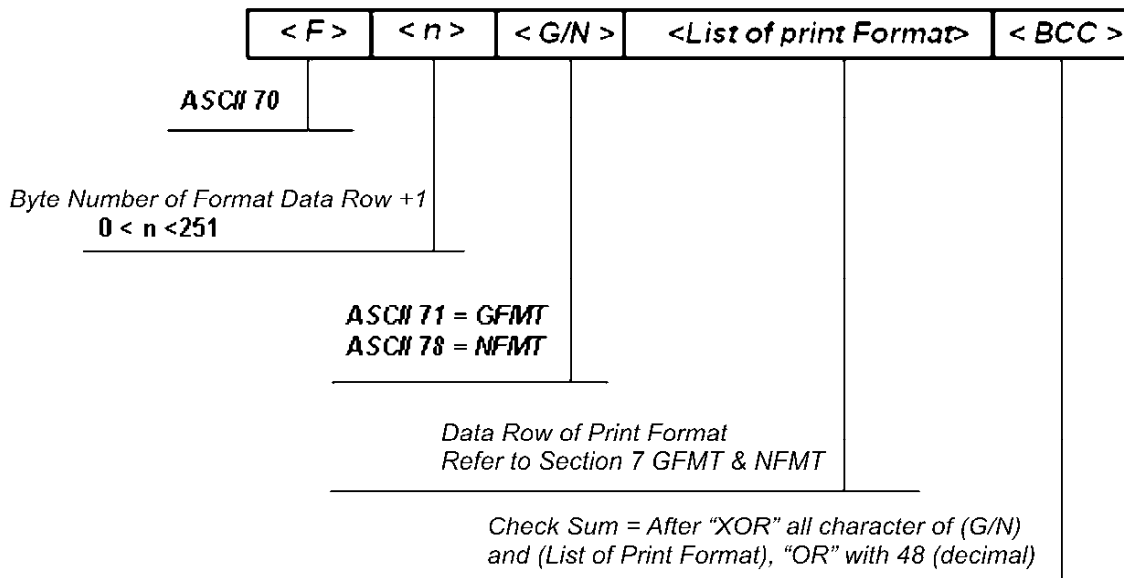

Fig. 8-6 Print Format Command Transmission Sequence

**Note:** When <G/N> is 'G' (ASCII 72), the format followed is the gross weight print mode (GFMT). When <G/N> is 'N' (ASCII 78), the format followed is the net weight print mode (NFMT). Refer to Section 7 regarding GFMT and NFMT.

Indicator respond format: Correct transmission "OK", Incorrect transmission "??".

Example: PC sends gross weight print command to indicator <G>GROSS<NL><E>

PC sends:





01H, 31H, 02H, **46H, 10H, 47H, 3CH, 47H, 3EH, 47H, 52H, 4FH, 53H, 53H, 3CH, 4EH, 4CH, 3EH, 3CH, 45H, 3EH, 3FH**

Indicator responds : 01H, 31H, 02H, **4FH, 4BH, 03H, 37H**

### 8.3 Serial Communication Tests

Connect 2 indicators, A and B, according to Fig. 8-7. Set indicator A to Data Transmitted upon Request (F4.4=1) according to Section 8.1, and set the same parameters for F4.1, F4.2 and F4.3 of both indicators.

Perform serial communication test as follow :

- (1) Turn on the K1 switch to set indicator B to the Configuration mode. B display shows "F1".
- (2) Press  until B display shows "F4" (see Fig. 8-1). Press  to go to F4 Menu. B display shows "F4.1".
- (3) When B display shows "F4.1", press  until B display shows "F4.5".
- (4) When B display shows "F4.5", press . B indicator sends command to A indicator,

and receives response data from A indicator. There are following possible outcomes:

- After B indicator sends command, A indicator gives no response and B display shows “EC”.
  - B indicator receives error message and B display shows “Er”.
  - B indicator receives proper data from A indicator, both displays show identical message.
- (5) Turn off the K1 switch to exit from Calibration mode and enter into Weighing Mode.

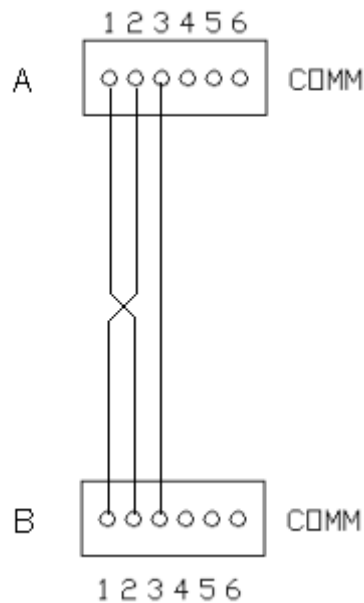

Fig. 8-7 Serial Communication Test

## 9. Appendix

### 9.1 Error Messages

When an error occurs, the message is shown on the indicator LED display. Error message codes are shown in Table 9-1.

Table 9-1 Error Message Code and Solution

Error Message	Description	Solution
-- E 0 --	Data too big after changing units	Check decimal setting in primary and secondary units. Refer Section 3.2.2 regarding F2 Menu

-- E 1 --	Incorrect operating parameters	Check parameters according to Section 3
-- E 2 --	A/D exchange error S	Check hardware by qualified personnel
-- E 3 --	Data reading error	Check hardware by qualified personnel
-- E 4 --	A/D transfer start up error	Check hardware by qualified personnel
-- E 5 --	Count item average weight too small	Check scale range or increase sampling weight according to Section 5
-- E 6 --	No average weight set for count items	Refer to Section 5 to set average weight
-- E 7 --	Load cell input signal > 20mV	Check load cell and connecting cables
-- EL --	Load cell input signal < -4mV	Check load cell and connecting cables
-- OF --	Load value > F1.5 Set value	Reduce load on scale

## 9.2 Software Version and Default Configuration Parameters

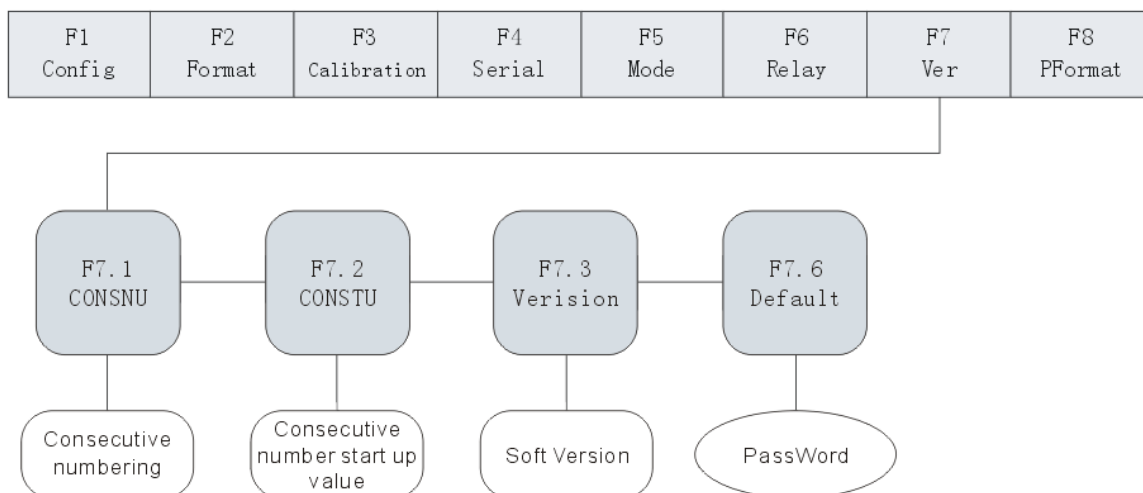















Fig. 9-1 F7(Ver) Menu

### 9.2.1 Find out indicator software version

- (1) Turn on the K1 switch to set indicator to the Configuration mode. Display shows "F 1".

- (2) Press  until display shows "F 7" (see Fig. 9-1). Press  to go to F7 Menu. Display shows "F 7.1". Press  twice until display shows "F 7.3".
- (3) When indicator shows "F 7.3", press  again, display shows the current software version "XX.XX". Software version cannot be edited.
- (4) Press  to return to F7.3 Menu. Display shows "F 7.3".
- (5) Turn off the K1 switch to exit from Calibration mode and enter into Weighing Mode.

### 9.2.2 Restore Factory Setup Parameters (Default Configuration Parameters)

- (1) Turn on the K1 switch to set indicator to the Configuration mode. Display shows "F 1".
- (2) Press  until display shows "F 7" (see Fig. 9-1). Press  to show "F 7.1". Press  until display shows "F 7.6".
- (3) When display shows "F 7.6", press . Display shows a 4 digit code "==0000". Edit it to "0711" according to Fig. 4-2. Press .
- (4) There are 2 possible outcomes:
  - If input code is correct, display shows "Set ?" Then there are 2 options:
    - Press  to restore parameters to factory setup and return to F7.6 Menu. Display shows "F 7.6".
    - Press , give up restoring factory setup and return to F7.6Menu. Display shows "F 7.6".
  - If input code is incorrect, display shows "Err". Then there are 2 options:
    - Press , display shows a 4 digit code "==0000". Return to step (3) above and re-enter the code.
    - Press , give up restoring factory setup and return to F7.6 Menu. Display shows "F 7.6".
- (5) When indicator shows "F 7.6", turn off the K1 switch to exit from Calibration mode and enter into Weighing Mode.

### 9.3 Technical Specifications

A/D sampling rate	7.5 times/sec~960times/sec selectable
internal resolution	24bits
non-linearity	≤0.005%F.S
zero return	≤0.1μV/°C
temperature effect	≤5ppm/°C
full scale input signal	2~20mV

range of scale initial signal	-1~+9mV
input signal sensitivity	0.2uV /d (minimum) 1.5uV/d (recommended)
zero scale range	±1.9%FS、±100%FS selectable
tare range	0 ~ +100%FS
operating temperature	-10°C ~ 40°C
operating humidity	≧ 90% (without dew)
supply power source	
with transformer	AC220V (-15%~ +10%) , 0.2A
without transformer	DC 6V~8.5V, 1A
relay current	DC 28V, 2A; AC 220V, 1A
load cell bridge voltage	DC 5V can be connected to 16 cells of not less than 700Ω or 8 cells of not less than 350Ω

## 9.4 ASCII Codes Table

Control	ASCII	Dec	Hex	ASCII	Dec	Hex	ASCII	Dec	Hex	ASCII	Dec	Hex
Ctrl-@	NUL	00	00	space	32	20	@	64	40	`	96	60
Ctrl-A	SOH	01	01	!	33	21	A	65	41	a	97	61
Ctrl-B	STX	02	02	"	34	22	B	66	42	b	98	62
Ctrl-C	ETX	03	03	#	35	23	C	67	43	c	99	63
Ctrl-D	EOT	04	04	\$	36	24	D	68	44	d	100	64
Ctrl-E	ENQ	05	05	%	37	25	E	69	45	e	101	65
Ctrl-F	ACK	06	06	&	38	26	F	70	46	f	102	66
Ctrl-G	BEL	07	07	'	39	27	G	71	47	g	103	67
Ctrl-H	BS	08	08	(	40	28	H	72	48	h	104	68
Ctrl-I	HT	09	09	)	41	29	I	73	49	i	105	69
Ctrl-J	LF	10	0A	*	42	2A	J	74	4A	j	106	6A
Ctrl-K	VT	11	0B	+	43	2B	K	75	4B	k	107	6B
Ctrl-L	FF	12	0C	,	44	2C	L	76	4C	l	108	6C
Ctrl-M	CR	13	0D	-	45	2D	M	77	4D	m	109	6D
Ctrl-N	SO	14	0E	.	46	2E	N	78	4E	n	110	6E
Ctrl-O	SI	15	0F	/	47	2F	O	79	4F	o	111	6F
Ctrl-P	DLE	16	10	0	48	30	P	80	50	p	112	70
Ctrl-Q	DC1	17	11	1	49	31	Q	81	51	q	113	71
Ctrl-R	DC2	18	12	2	50	32	R	82	52	r	114	72
Ctrl-S	DC3	19	13	3	51	33	S	83	53	s	115	73
Ctrl-T	DC4	20	14	4	52	34	T	84	54	t	116	74
Ctrl-U	NAK	21	15	5	53	35	U	85	55	u	117	75
Ctrl-V	SYN	22	16	6	54	36	V	86	56	v	118	76
Ctrl-W	ETB	23	17	7	55	37	W	87	57	w	119	77
Ctrl-X	CAN	24	18	8	56	38	X	88	58	x	120	78
Ctrl-Y	EM	25	19	9	57	39	Y	89	59	y	121	79
Ctrl-Z	SUB	26	1A	:	58	3A	Z	90	5A	z	122	7A
Ctrl-[	ESC	27	1B	;	59	3B	[	91	5B	{	123	7B
Ctrl-\	FS	28	1C	<	60	3C	\	92	5C		124	7C
Ctrl-]	GS	29	1D	=	61	3D	]	93	5D	}	125	7D
Ctrl-^	RS	30	1E	>	62	3E	^	94	5E	~	126	7E
Ctrl-_	US	31	1F	?	63	3F	_	95	5F	DEL	127	7F

## 9.5 805TS Display Characters

!	-	9	E	Q
“	. .	:	F	R
#	/	;	G	S
\$	0	<	H	T
%	1	=	I	U
&	2	>	J	V
'	3	?	K	W
(	4	@	L	X
)	5	A	M	Y
*	6	B	N	Z
+	7	C	O	[
,	8	D	P	\